

MARCH 2024



AEROBIC RESIDENTIAL WASTEWATER TREATMENT SYSTEM

INSTALLATION, OPERATION AND MAINTENANCE MANUAL



Certified to
NSF/ANSI Standard 40



INFILTRATOR
water technologies

Infiltrator Water Technologies
4 Business Park Road
P.O. Box 768
Old Saybrook, CT 06475-0768
(800) 221-4436
www.infiltratorwater.com
info@infiltratorwater.com

TABLE OF CONTENTS

Important Notes.....	2
ENVIRO-AIRE™ Treatment Systems Notice.....	3
Introduction.....	5
Installation Instructions.....	8
Troubleshooting Guide	11
ENVIRO-AIRE Unit Specifications	12
Installer Checklist.....	16
Service Provider Checklist.....	17
Data Plates	18
Warranty	19

IMPORTANT NOTES

1. The Infiltrator Water Technologies Model EA50 has been tested by NSF International and conforms to NSF/ANSI 40, class 1 effluent requirements. All other EA models are certified based on provisions in the standard for certification of a series of plants of the same model varying only in rated treatment capacity and materials of construction.
2. State and/or local regulations govern the installation and use of individual aerobic wastewater treatment systems and must be complied with.
3. Consult your local Sanitarian/Regulatory Agency prior to installation.
4. **FOR INSTALLATION OF ENVIRO-AIRE IN INFILTRATOR TANKS ONLY:** An Infiltrator Authorized Assembler shall perform the assembly of the Infiltrator treatment system. Please call (800) 221-4436 with any questions.
5. **FOR INSTALLATION OF ENVIRO-AIRE IN CONCRETE TANKS ONLY:** If the concrete tank is delivered to the site without the ENVIRO-AIRE pre-installed in the tank, please contact your distributor.
6. This manual provides installation information on the **TREATMENT PLANT ONLY**. Other components, such as dosing equipment or drip irrigation, have separate manuals and warranties. The installer is responsible for providing the manual and warranty information for each component in your system. Contact your installer or (800) 221-4436.
7. **NOTE TO INSTALLER:** Complete the **HOMEOWNER RECORDS** form below and provide this manual to the homeowner.

HOMEOWNER RECORDS

S/N: _____ DATE OF INSTALLATION: _____

INSTALLED BY: _____

DISTRIBUTOR: _____

ENVIRO-AIRE TREATMENT SYSTEMS NOTICE

To be completed by the installer and provided to the homeowner. ENVIRO-AIRE TREATMENT SYSTEMS NOTICE

This manual provides operations, installation and warranty information on the **TREATMENT PLANT ONLY**. Other components that you may have, such as dosing equipment, drip irrigation or other components, require additional operations manuals and carry separate warranties.

Be sure that you have all of the correct manuals for each of the component pieces in your system.

Contact your installer or call (800) 221-4436.

INFILTRATOR TREATMENT SYSTEMS QUALITY ASSURANCE TAG

S/N: _____ DATE OF INSTALLATION: _____

AERATOR PACKAGE COMPLETE: _____
(Initial)

INTERNAL ASSEMBLY: AIR DROP LINES COMPLETE AND SECURED: _____
(Initial)

ENVIRO-AIRE TREATMENT SYSTEM NOTICE

ENVIRO-AIRE TREATMENT SYSTEMS NOTICE

This home is served by an individual wastewater treatment system. This system will serve you well only if it is properly maintained. Your system is comprised of:

Your system is located:

Please do not build on, fill over, allow heavy traffic or allow water to stand over this area. Avoid using strong chemicals, sanitizers, cleaning fluids, etc., which will kill helpful bacteria in the system. You should also avoid flushing grease, food scraps, cigarette butts, sanitary napkins, and other inorganic waste down the drain.

You should have your system serviced (pumped out) every 3 to 5 years, depending on usage. Your service technician can advise you if you need more frequent or additional service.

To have your system serviced, or for additional information, contact Infiltrator Water Technologies at (800) 221-4436.

All of the details regarding system operation can be found in this manual. If you did not receive a copy, call Infiltrator Water Technologies at (800) 221-4436 or email info@infiltratorwater.com and we will send you one at no charge.

Keep a Record of Service Below:

DATE	SERVICE PERFORMED	SERVICE TECHNICIAN

INTRODUCTION

THE INFILTRATOR AEROBIC WASTEWATER TREATMENT SYSTEM AND HOW IT WORKS

The ENVIRO-AIRE Aerobic Wastewater Treatment System that you have purchased produces high quality effluent suitable for various disposal methods. It is used to enhance your on-site wastewater treatment system. You can be proud that in purchasing your ENVIRO-AIRE System, with a minimum amount of maintenance, you can directly contribute to a cleaner, safer environment.

All wastewater treatment systems of this type work by using the bacteria that nature has provided. By pumping air into the system, the bacteria grow and thrive in much larger amounts than would occur naturally. The increased population of bacteria speeds up the process of treating domestic wastewater which makes it safe to release into the environment. This entire process takes place within the walls of your specially designed ENVIRO-AIRE Treatment System.

Your ENVIRO-AIRE consists of three chambers contained in one treatment system: pretreatment, aeration/mixing, and clarifier. Domestic wastewater enters the pretreatment chamber where solids settle out of the raw wastewater. The effluent then flows into the aeration/mixing chamber. Mixing and aeration are accomplished by air introduced by the aerator via the air manifold located in this chamber. The mixed liquid then enters the clarification chamber through an opening at the bottom of the baffle wall. The quiet conditions in this chamber allows any remaining solids to settle to the bottom and reenter the mixing chamber before exiting to the drainfield. The result of this process is a clear, odorless discharge, which meets or exceeds state water quality standards for CBOD₅ and TSS.

By following the few simple steps that you find in this manual, your ENVIRO-AIRE System will provide you with years of service and the knowledge that you are doing your part to protect our groundwater, lakes, rivers and streams.

HOMEOWNER CARE AND OPERATION INSTRUCTIONS

The ENVIRO-AIRE System has been designed and built to provide long term, reliable and efficient service. Once the unit has been installed (see installation instructions), the unit will operate with a minimal amount of attention.

Please reference the system's Data Plates for serial number that are located on the aerator, and the alarm panel in the event that a problem arises or service is required. Call (800) 221-4436 for your local service provider's contact information.

STANDARD MAINTENANCE SCHEDULE

Every six months for the first two years after installation, annually after the initial two years. Performed by a certified service provider.

- Inspect and make any necessary adjustments to mechanical and electrical components.
- Inspect the air filter on the aerator. Rinse with warm water if necessary. Do not use oil or other solvents. Allow the air filter to dry before restarting the system.

- Inspect effluent quality's color, turbidity, and check for odor. An earthy odor is normal.
- Take a sample from the pretreatment treatment system and aeration chamber to check the sludge level described in the "Solids Removal" section below.

THE FOLLOWING ARE INDICATIONS THE SYSTEM MAY REQUIRE SERVICE:

Warning Device

The visual and audio warning device comes on when the power to the aerator has been interrupted, when the air supply system has malfunctioned, or there is a high-water level in the treatment plant. If the alarm is activated, check for a tripped GFI, blown fuse or thrown circuit breaker. Ensure the aerator is operating properly. Once accustomed to the soft humming sound of a properly operating unit, any unusual noise is an indication of malfunction. If an unusual noise is detected or total failure is observed, call an authorized Infiltrator service provider or dealer/distributor.

Odors

Offensive odors may indicate the system is not functioning properly. If such a condition should develop, call a certified service provider or dealer/distributor.

The homeowner must be notified in writing if any improper operation is observed and cannot be corrected at the time of service.

TO KEEP MAINTENANCE TO A MINIMUM AND ENSURE HIGH EFFLUENT QUALITY THE FOLLOWING SHOULD NOT BE USED OR DISCARDED INTO THE SYSTEM

Do not discard the following into the system:

- Greases, fats, oils
- Pesticides, herbicides, or any other toxins
- Paints, household chemicals, automobile fluids or mop water
- Non-biodegradable items such as cigarette butts, rags, feminine hygiene products, disposable diapers, condoms, hair, bandages, coffee grounds, paper towels, plastic or metallic objects, etc.
- Citrus products, oranges, lemons, grapefruit, etc.
- Septic system additives as they may do more harm than good
- Hydraulic overload due to excessive water use or inflow from other sources such as rain gutters or leaky fixtures (toilet, sink)
- Home brewery waste, strong medicines, and antibiotics
- Strong disinfectants, bleaches or laundry products
- Discharge from water softeners
- Antibacterial soaps should be avoided
- Recommended detergents are powdered, low-sudsing, low phosphates and biodegradable, washing soda ingredients

INTRODUCTION

Fabric softener dryer sheets are recommended rather than using liquid fabric softeners.

- Use non-chlorine, biodegradable and non-toxic cleaning products, dish washing liquids, powdered dishwasher detergents, or powdered cleaners and baking soda.
- Use garbage disposals sparingly. Dispose of food waste, grease, etc., in the solid waste bin. Food waste represents additional matter your wastewater treatment system will have to digest, increasing pump-out intervals.
- Laundry loads should be spread out over the week. Multiple loads on one day or half loads are not recommended.

Systems requiring pump-outs due to the above violations are not covered by the warranty.

The ENVIRO-AIRE System is designed to handle domestic wastewater only. For anything other than domestic wastewater, contact Infiltrator Water Technologies.

WARNINGS

- The proper operation of this or any other home sewage system depends upon proper organic loading and the life of the microorganisms inside the system. Infiltrator Water Technologies is not responsible for the in-field operation of a system, other than the mechanical and structural workings of the plant itself. We cannot control the amount of harsh chemicals or other harmful substances that may be discharged into the system by the occupants of a household. We can provide only a comprehensive owner's manual that outlines substances that should be kept out of the system.
- Hydraulic overloading (flows in excess of design flow) may cause your system not to perform to the fullest capabilities.
- Lack of maintenance, including not cleaning the aerator's filter will cause damage and is not covered under the manufacturer's warranty.
- Ants have been shown to be destructive to the aerator. Regular care should be taken to prevent infestation of ants near the system. Damage or destruction by ants is not covered under manufacturer's warranty.
- Your state or local health department may require other components that operate separately or in conjunction with equipment manufactured by Infiltrator Water Technologies. Infiltrator Water Technologies is not responsible for the mechanical or electrical operation or safety of equipment it does not manufacture or supply with its aerobic treatment units. Particular care should be used in evaluating the electrical or mechanical safety of equipment manufactured by others. This may include but not be limited to electrical control panels or aerators.
- If electrical service has not been installed for checking the air distribution system during installation, and if an extension cord is used to test the aerator, DO NOT leave the extension cord plugged in. Remove it after testing is completed.
- Due to a possible fire hazard, DO NOT plug into service equipment on power pole and DO NOT use extension cords. For any use other than as described above. All electrical work performed by the installer or others must be in accordance with the National Electrical Code (NEC) and local codes.
- The operation and maintenance outlined in this manual

applies to normal operating conditions. Extreme conditions such as frigid cold temperature, extreme heat and high altitudes may affect the operation and maintenance of this unit. Consult Infiltrator Water Technologies personnel or authorized representative regarding these extreme conditions.

WARNING Failure to properly secure treatment plant lids may result in a serious health and/or safety hazard.

SOLIDS REMOVAL

Determination of the need for solids removal can be done using either of the following two methods

Sludge Judge

Before you begin, turn off power to the aerator and let the system rest for 15 minutes, allowing the suspended solids to settle at the bottom of the aeration chamber. Remove the treatment system lid and lower the sludge judge to the bottom of the treatment system. The float valve will open, allowing liquid to enter the tube. When filled, tug slightly on the line as the unit is raised which sets the check valve. If the sludge judge indicates more than 12 inches of sludge in the bottom of the treatment system, the treatment system should be pumped out. Call your local authorized sewage disposal service to have the treatment system contents pumped out and disposed of properly.

Settleability Test (alternative option to a sludge judge test)

Collect a sample from the aeration chamber of the treatment system through the access riser using a clear one-quart jar. The aerator must be operating to keep solids in suspension. Allow the sample to settle for thirty minutes. If the solids content exceeds 60% of the total volume after settling, the wastewater treatment plant should be pumped out. Call your local authorized sewage disposal service to have the treatment system contents pumped out and disposed of properly.

Pumping Method

- Be sure the power to the aerator is off before you begin pumping.
- It is recommended that the primary chamber always be pumped, prior to pumping the aeration chamber removing all solids.
- Remove any floating solids by skimming.
- Pump out two-thirds of the aeration chamber volume with the suction pipe opening being placed at the treatment system bottom.

After the pump-out process is complete, fill the treatment system with fresh water to normal operating level.

Refer to the Installation Instructions to return the wastewater treatment plant back to operation.

The homeowner must be notified in writing if any improper operation is observed and cannot be corrected at the time of service.

Note: Costs associated with pumping are not covered the under warranty and are not included in the service policy.

INTRODUCTION

SEASONAL USE GUIDELINES OF ENVIRO-AIRE AEROBIC TREATMENT UNIT

1. System not in use for more than one month and less than three months. Electrical power is left on and there are no frost conditions.
 - Leave aerator on and system running.
2. System not in use more than three months. Electrical power is turned off and there are not frost conditions.
 - Turn off aerator.
 - Remove all material and liquid from treatment system.
 - Refill with clean water.
 - When system is back in use turn on aerator.
3. System not in use more than three months. Electrical power is on and there are not frost conditions.
 - Leave aerator on and system running.
 - OR, Turn off aerator, remove all material and liquid from treatment system.
 - Refill with clean water.
 - When system is back in use turn on aerator.
4. System not in use. Electrical power is turned off and there are frost conditions.
 - Turn off aerator.
 - Remove all material and liquid from treatment system.
 - If high groundwater is present, fill with clean water.
 - If no groundwater is present, leave treatment system empty.
Extremely cold climate only.
 - When system is back in use turn on aerator.

Under no circumstances should the aerator be turned off for more than a few days without removing treatment system contents!

Contact Infiltrator for recommendations if your site conditions are not covered by the above mentioned conditions.

SAMPLING REQUIREMENTS (if required to meet local regulation)

An ENVIRO-AIRE aerobic treatment plant properly operated and maintained should provide the following effluent quality of:

Carbonaceous Biochemical Oxygen Demand 5 day average (CBOD₅) of *less than 25 mg/l (or ppm)*

Total Suspended Solids (TSS) of *less than 30 mg/l (or ppm)*

Taking Effluent Samples

Sampling should be taken by a local certified testing laboratory or by following their procedures. The following recommended guidelines may be used if local procedures are not available:

Grab Samples: If analysis is begun within two hours of collection, cooling is unnecessary. If analysis is not started within two hours of sample collection, keep sample at or below 4°C from the time of collection. Begin analysis within six hours of collection; when this is not possible because the sampling site is distant from the laboratory, store at or below 4°C and report length and temperature of storage to the lab. Never start analysis more than 24 hours after grab sample collection. When samples are to be used for regulatory purposes, make every effort to deliver samples for analysis within six hours of collection.

Handle, store and transport samples as specified by policies and procedures provided by the testing laboratories.

Affix labels to sample bottles.

Ensure chain of custody forms are properly completed after samples are collected.

Procedures for collecting samples from the access riser:

1. Remove the access riser lid.
2. Quickly plunge sample collection dipper 2 to 3 inches below the water surface.
3. Remove the sample collection dipper, pour contents into the appropriate sample bottles, and immediately cap bottles.

Sample procedures for combination vent/sample port in the discharge line:

1. Prior to collecting sample have ENVIRO-AIRE Plant discharge effluent for up to four minutes by flushing toilets and/or use garden hose to flush out sample port.
2. Insert sample collecting bottle to collect only effluent which is cascading over the cascading edge.
3. Pour contents into the appropriate sample bottles and immediately cap bottles.

INSTALLATION INSTRUCTIONS

FOR USE BY CERTIFIED, LICENSED INSTALLERS

1. ENVIRO-AIRE Delivery and Handling

The ENVIRO-AIRE is delivered to the installation site assembled in an Infiltrator Tank or approved precast concrete tank. Care must be taken when offloading and unpacking the treatment system and components to ensure no damage occurs to the treatment system and components by forklift or any other offloading device. Check for damage that may have occurred in transportation and notify the factory or distributor within 24 hours of delivery.

2. Set Treatment System

Prepare the excavation and compact the base material before setting the treatment system. Set and position and level the treatment system in the proper location. Reference the Infiltrator IM- and CM-Series Septic Treatment system General Installation Instructions.

3. Plumb Treatment System Inlets and Outlets

Plumb and solvent weld all inlet and outlet piping. Inlet and outlet plumbing requirements are specified by state or local regulatory code.

The inlet piping should be sloped downward into the treatment system and the outlet piping should sloped downward and away from the treatment system or per code.

4. Backfilling the Treatment System

Backfill the treatment system in lifts of no more than 12 inches. Compact each lift up to the treatment system inlet and outlet pipes. Reference the Infiltrator IM- and CM-Series Tank Installation Instructions.

5. Fill Treatment System with Clean Water

Begin filling the treatment system with clean water while the air distribution and control panel assembly are completed. Continue filling the treatment system until water level reaches the outlet tee.

6. Treatment Systems Risers, Lids, Venting, and Sample Ports

Treatment System Lids: Finished grade should slope away from treatment system lids, vents, and sampling ports to prevent surface runoff from entering the system.

Treatment system lids must be securely attached with bolts, screws, or other locks to secure the lids and to prevent easy access. Optional secondary lid options are always highly recommended.

Sample Port: Sampling port must capture the free-falling effluent, downstream of the treatment system.

Venting: This system pumps air into a controlled space and requires a venting system or the system will not function properly and cause undue stress on various components. Install a 4-inch PVC pipe vent, exiting through the outlet riser brought above grade and capped with the supplied green atrium vent cap (or equivalent).

A charcoal filter, if used, should be installed on top of vent pipe.

7. Plumb Air Distribution System

Plumb in the air distribution system. Prime and solvent weld all connections. Bring ¾-inch Schedule 40 PVC line out of the tank through the riser sidewall. Extend PVC air distribution piping from the riser to where the aerator will be located. A minimum of 12-inch of ground cover is recommended over the air distribution piping. Connect the aerator to the PVC distribution piping

When connecting a linear aerator, attach ½-inch to ¾-inch Rubber Hose Adapter to the aerator outlet using the supplied hose clamps. Next, attach the ¾-inch PVC air distribution pipe to the ½-inch to ¾-inch Rubber Hose Adapter using the supplied hose clamp.



8. Aerator Placement

The aerator should be installed near the control panel (if applicable) and within 100 feet. of the treatment plant. The aerator can be installed outdoors or in a clean, well-ventilated area, such as a tool room, garage, etc., if allowed by state/local regulations. The location should be easily accessed and regularly observed to insure proper continual operation. Do not install the aerator(s) in a low-lying area where water may accumulate. If an aerator is to be installed in an additional, well ventilated enclosure, the enclosure must be approved by INFILTRATOR Treatment Systems in writing.

9. Control Panel (optional for EA52.5, required for EA75)

Note: The EA52.5 is supplied with the HP60A aerator as standard equipment that includes an integrated pressure switch, audible and visual alarm. The HP60A aerator assembly eliminates the need for a control panel with the EA52.5. All other models will require use of control panel.

Mount the control panel in a location where the alarm can be heard and be readily observed. The control panel must be connected to a 20-amp maximum electrical source equipped with a ground fault interrupter (GFI) circuit breaker. Install a power disconnect switch to the panel that is operable and available to a maintenance provider. The control panel must be

INSTALLATION INSTRUCTIONS

grounded by connecting the source ground wire to the ground location in the panel. All electrical work shall be done according to NEC and state/local code requirements with a licensed electrician where required.

- A. Attach control panel to a suitable mounting surface. Use appropriate screws for all four mounting holes on the back of the enclosure.
- B. The control panel contains a fuse or circuit breaker for the aerator. An electrical malfunction in the aerator, or wiring to the aerator, will cause the fuse or circuit breaker to blow. The control panel also contains a pressure switch and visual and audible alarms. Loss of air pressure caused by aerator system malfunction, or a high-water level in the treatment treatment system, will cause the alarm to sound and light to illuminate.
- C. The control panel is rated for outdoor service. However, do not place the panel in an area that can be immersed in rising water or where runoff from a roof, storm drain, etc. may collect. Do not mount the panel where it is subject to wetting from sprinklers, hoses, etc.
- D. Connect conduit. After properly mounting the control panel, connect the conduit and install wiring as shown on the control panel drawings (schematics).
- E. Connect the pressure air tubing to the 1/8-1inch barb-fitting in the air piping system. The air tubing should be protected by conduit as shown on the drawing.

minutes. Alarm should occur. Release air tubing and alarm should stop.

- F. In the event that a fuse blows, replace with time delay or slow blow, 125 volt minimum voltage rating and the same amp rating as the existing fuse.
- G. Replace and secure all treatment system access lids. Close up the enclosure door on control panel and lock if applicable
- H. Spend time with your customer whenever possible. Review operation instructions and provide the customer with a copy of the operation and maintenance and homeowner's sections of this manual. This saves valuable time avoiding return visits.

10. System Startup

Once the treatment system water level reaches the outlet tee, turn power on to aerator or control panel if applicable. Aerator should power on and begin making a quiet humming sound and the aeration chamber should begin to bubble.

If applicable, set the high level pressure switch in the control panel. Note: If your installation is using the HP60A this step is not necessary.

Complete filling the treatment system and power on the aerator. Using a properly sized screwdriver, turn high level alarm adjustment screw clockwise until alarm sounds. Then turn the screw counterclockwise until alarm stops.

- A. Check air piping joints for leakage by spraying the joints with a soapy water solution. Repair if necessary and then carefully backfill around air distribution piping and treatment systems.
- B. Recheck water level in the treatment system.
- C. Finish grade the site. Divert surface water away from the system and install or plant ground cover to prevent erosion.
- D. The treatment system is ready to receive incoming sewage. No special start-up procedures are required. The process is naturally occurring and does not require any special additives.
- E. Test alarm circuit by momentarily squeezing air tubing and allowing air pressure to decrease. This should take a few

INSTALLATION INSTRUCTIONS: VENT AND SAMPLE PORT INSTALLATION

There are two (2) options for the location of the vent. The preferred vent location is through the riser.

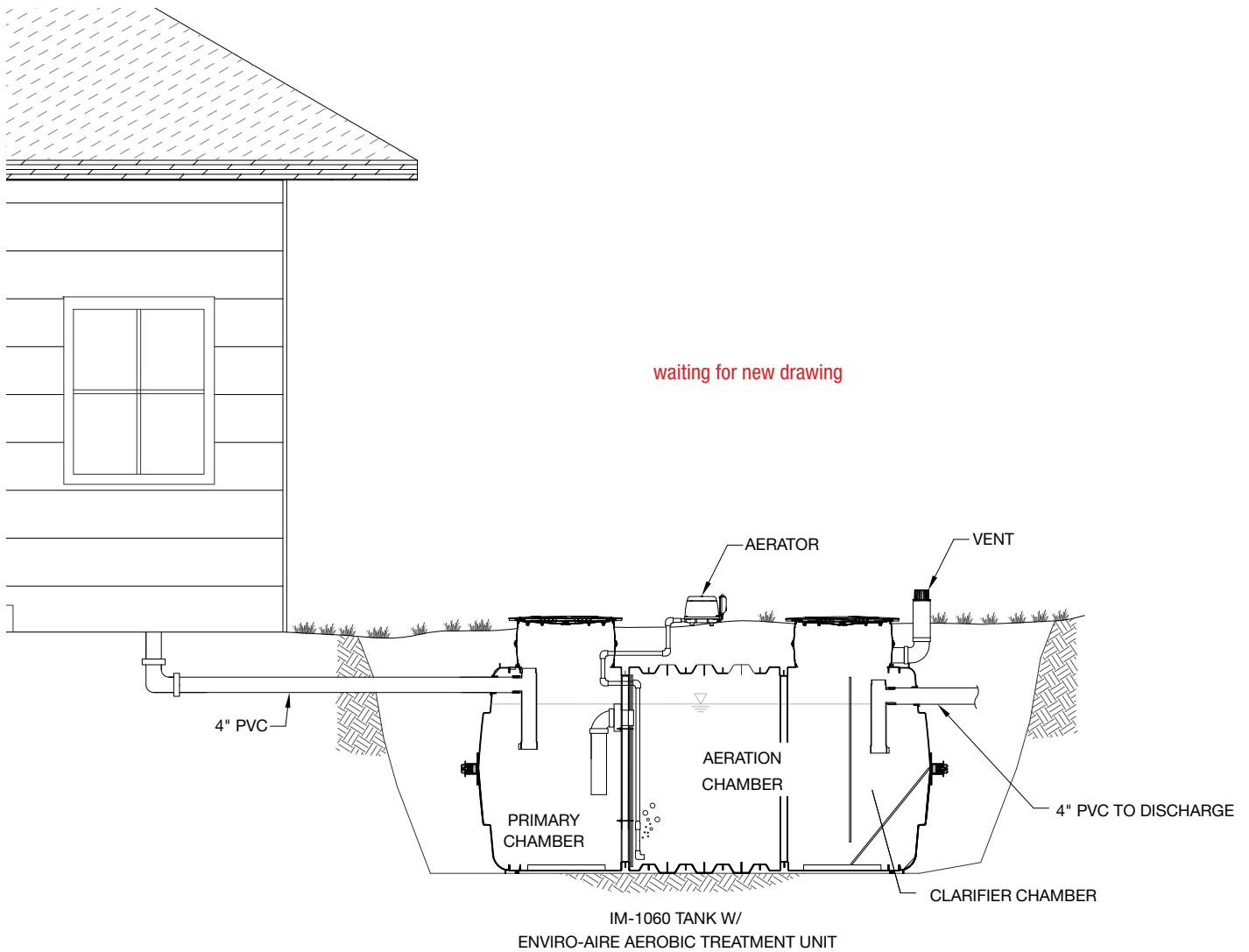

Examples of sample ports and vents.

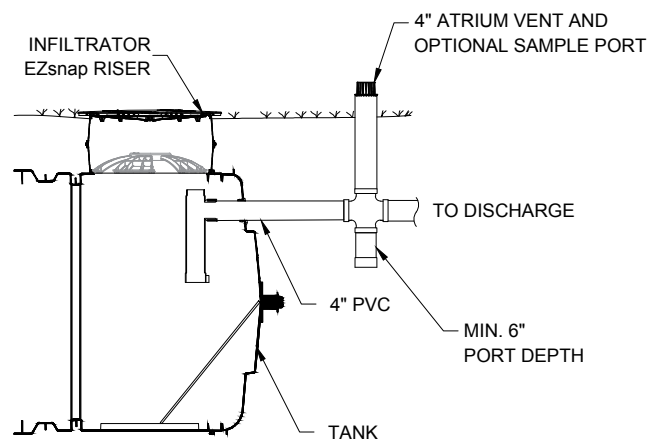
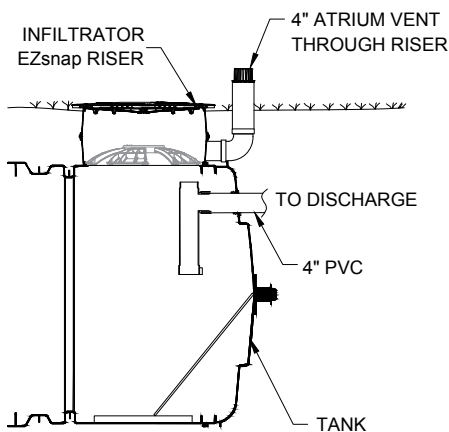

TROUBLE SHOOTING

AIR SUPPLY MALFUNCTION

1. Check to be sure the air manifold are working properly. It should be bubbling evenly and forcefully. A septic (rotten egg) odor could mean that the system is not getting enough air. If the the air manifold is not working, partially working (slight bubbles), check the following:

- a. Check to be sure the aerator is working.
 - check to see if the GFI has been tripped
 - check the electrical source
 - if electrical source is OK, check service guide for aerator troubleshooting information
 - wash air filter on aerator
 - consult manufacturer for servicing information
- b. Check to be sure treatment system is not severely out of level. Air follows a path of least resistance.
- c. Check for broken or cracked air lines both outside and inside the treatment system.
- d. Ants will destroy an aerator. Check to see if there is an ant nest around the aerator.
- e. Always check to see if inlet and outlet lines are correctly installed.

2. Alarm does not occur when aerator is off:
- a. Malfunctioning light or buzzer – replace.
 - b. Malfunctioning pressure switch – replace.

INTERNAL ASSEMBLY MALFUNCTION

1. Raw, untreated sewage from the aeration chamber (bubble zone) should not enter the clarifier (quiet zone) because of improperly installed or loose baffles. Check the treatment system to make sure construction is correct.
2. Check to be sure all internal piping and connections are tight.

DESIGN OVERLOAD

1. The system could be hydraulically overloaded (there is too much water going through the system for the size of the system).
2. The system could be organically overloaded (there is too much waste for the size of the system).

VISUAL INSPECTION

1. Water in the aeration chamber (bubble zone) should be the color of chocolate milk. Blue or gray/blue water indicates heavy use of detergents or other chemicals. If water appears sudsy, there is too much detergent being used.
2. Water in the clarifier (quiet zone) should be clear, although scum and debris may appear on the surface; this is normal. Water enters the discharge tee 16 inches below water surface.

3. Do not allow excess amounts of oil and grease to enter the system. Grease tends to form in white balls.

TROUBLESHOOTING ELECTRICAL SYSTEM

1. Reset GFI outlet if applicable.
2. Confirm aerator has power and confirm power is reaching electrical components.
3. Aerator does not run: Check main service for power.
4. Alarm occurs continuously even when aerator is running:
 - a. Air leak in main air system or air tubing to pressure switch – repair leak or replace air line.
 - b. Malfunctioning pressure switch – replace.
 - c. High water level in treatment system – inspect for cause.

NOTE: All replacement parts are available from your local dealer.

CAUTION: Electrical shock or hazard may occur if unit is not serviced properly. The manufacturer recommends that a licensed electrician be called when electrical problems occur.

COMPONENT REPLACEMENT PROCEDURE

- **Aerator:** Follow the same procedure as outlined in the “Installation Instructions”.
- **Pressure Switch (if applicable):** Turn all power off to the control panel. Remove control panel mounting. Remove screws securing pressure switch as well as connectors and tubing. Reverse procedure to install new pressure switch.
- **Audible Alarm:** Turn all power off to the control panel. Remove screw attaching alarm to panel as well as connectors. Reverse procedure to install new alarm.
- **Alarm Light Holder:** Turn all power off to control power. Remove lock nut securing light holder as well as connectors. Remove lamp holder. Install new light holder with gaskets furnished. Continue with reverse procedure.
- **Alarm Light Bulb:** Turn all power off to control panel. Remove red light cover. Remove and replace bulb, which is a push-in type. Replace light cover and cover gasket.
- **Circuit Breaker:** Turn all power off to control panel. Remove fasteners securing circuit breakers as well as connectors.

TROUBLE SHOOTING

GENERAL COMMENTS

- Only factory-approved equipment can be used for replacement on individual treatment systems.
- If the decision is made to pump out a system, be sure to contact a licensed waste hauler.
- If a chronic problem develops and all items have been checked, consult Infiltrator or an authorized representative.
- Keep good records.

SPECIFICATIONS

Treatment Plant	Treatment Capacity (gpd)	Total Volume (Gal)	Primary Volume (Gal)	Aeration Volume (Gal)	Clarifier Volume (Gal)
EA50	500	1,113	346	584	186
EA52.5-IM1060	525	1,142	350	597	195
EA60*	600	1,670	512	879	279
EA75	750	1,670	512	879	279
EA75-IM1530	750	1,604	515	813	276
EA80	800	1,804	550-750	935	319

* May be installed in an IM-1530 or concrete tank.

The incoming power supply to the Infiltrator Supplied Control Panel and Equipment must be verified prior to it being energized. Incoming power shall match Infiltrator Supplied Equipment's ratings. Refer to motor nameplates and Control Panel wiring diagram for amperage and voltage verification. The contractor is responsible to ensure that proper power, wiring, conduit, metering equipment, and weather proof connections are installed according to the engineer's specifications, local codes, and the NEC.

ELECTRICAL REQUIREMENTS

Model	Aerator	Motor full load Amps	Measured Operating Watts	Electrical Requirements
EA50	HP60A About 2.1 CFM at 2.13 PSI*	1.3	51	115 volt – single phase
EA52.5	HP60A About 2.1 CFM at 2.13 PSI*	1.3	51	115 volt – single phase
EA60	HP80 About 2.8 CFM at 2.13 PSI*	1.6	71	115 volt – single phase
EA75	HP100L About 3.5 CFM at 2.13 PSI*	1.9	75	115 volt – single phase
EA80	HP100L About 3.5 CFM at 2.13 PSI*	1.9	75	115 volt – single phase

*PSI is relative to the water depth within the tank.

FLOW DIAGRAM

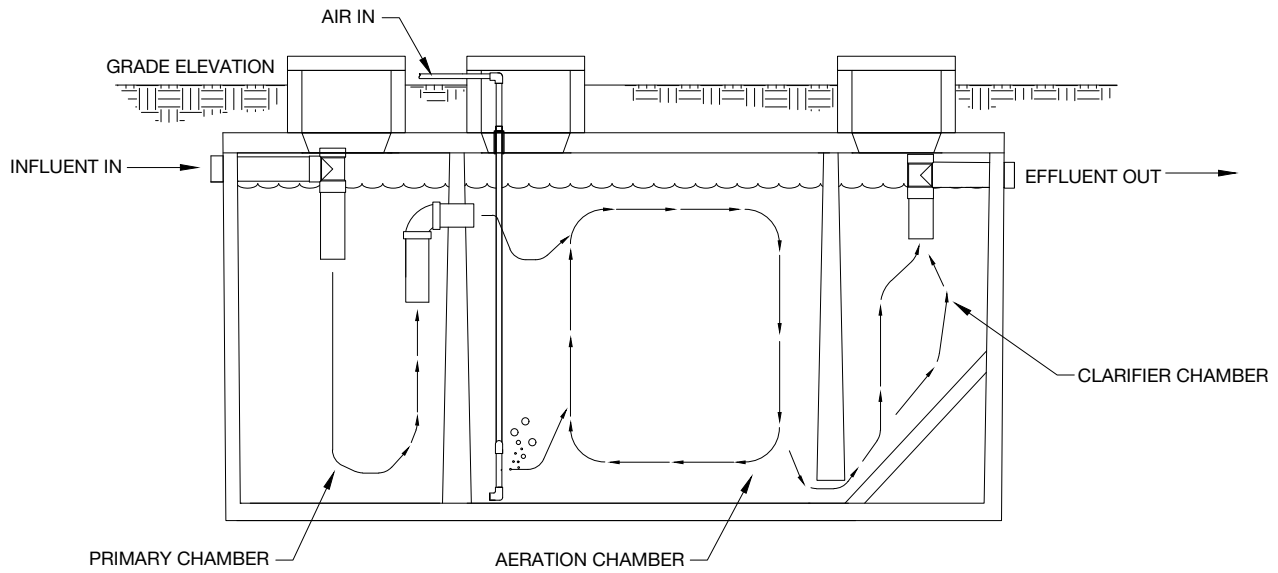

MINIMUM SPECIFICATIONS – EA50, EA60, EA75 AND EA80 IN CONCRETE TANK ONLY

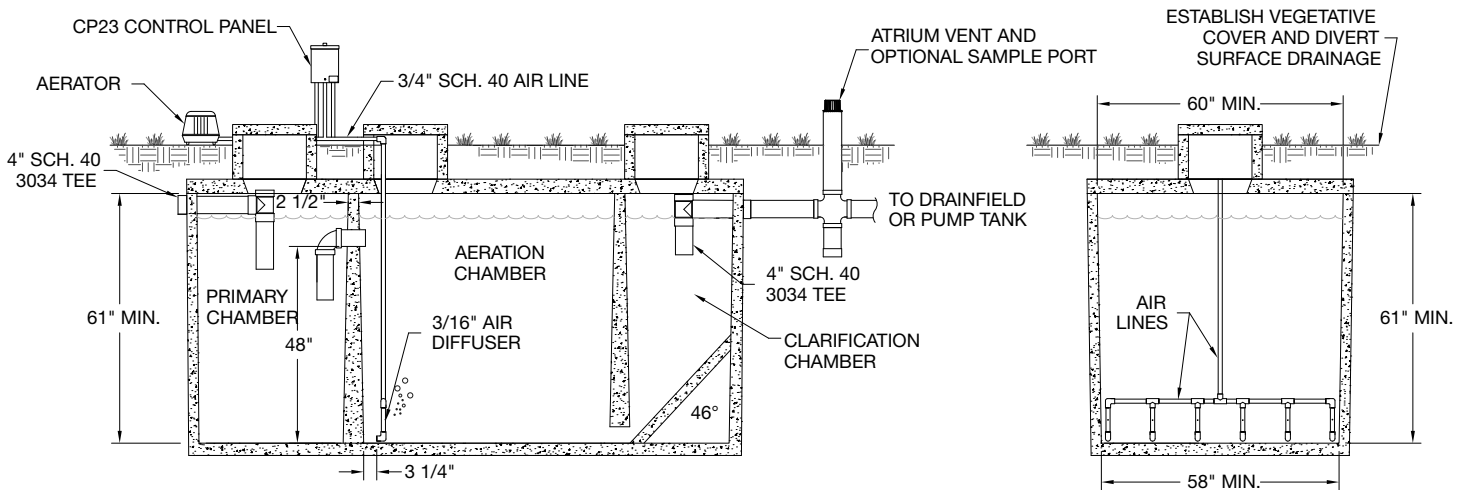

NOTES

1. Install tank per precaster instructions.
2. If precast dimensions are outside the minimum dimensions, contact Infiltrator for review.
3. For designs with treatment capacities greater than 800 gpd, contact Infiltrator for review.

SPECIFICATIONS CM-1060 ONLY LAYOUT

NOTE: Vent must be installed. See page 10 for options.

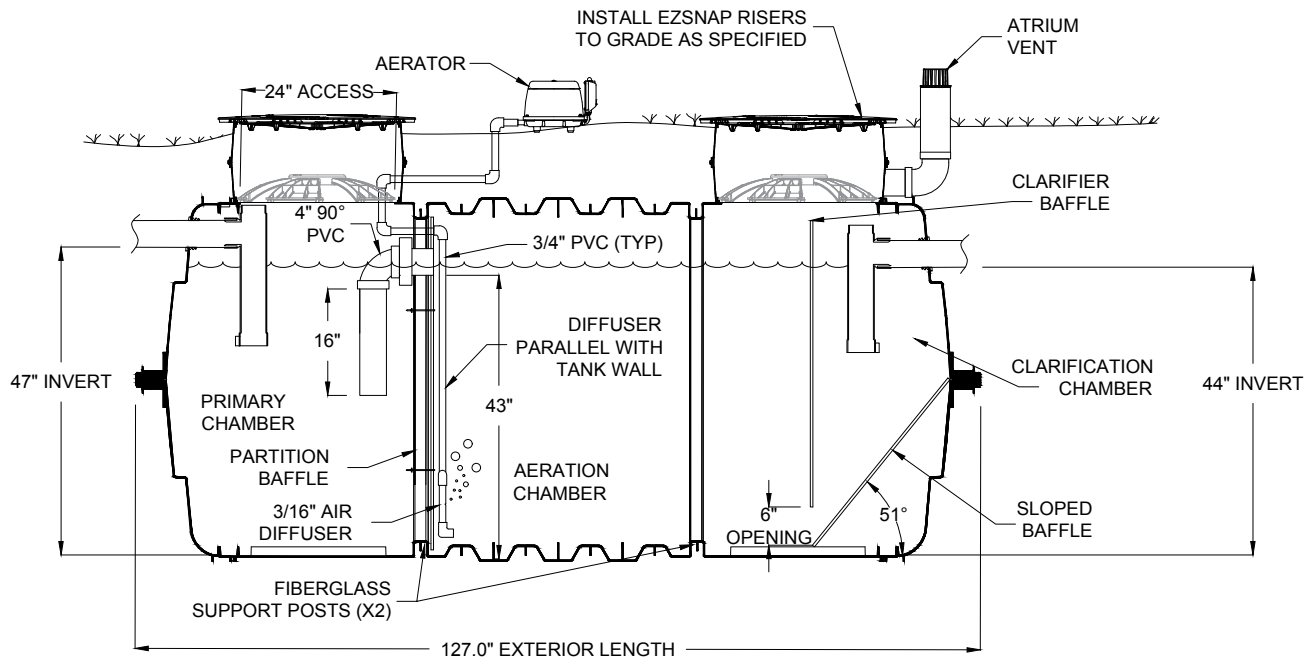

SPECIFICATIONS E60 AND E75 IM-1530 LAYOUT

NOTE: Vent must be installed. See page 10 for options.

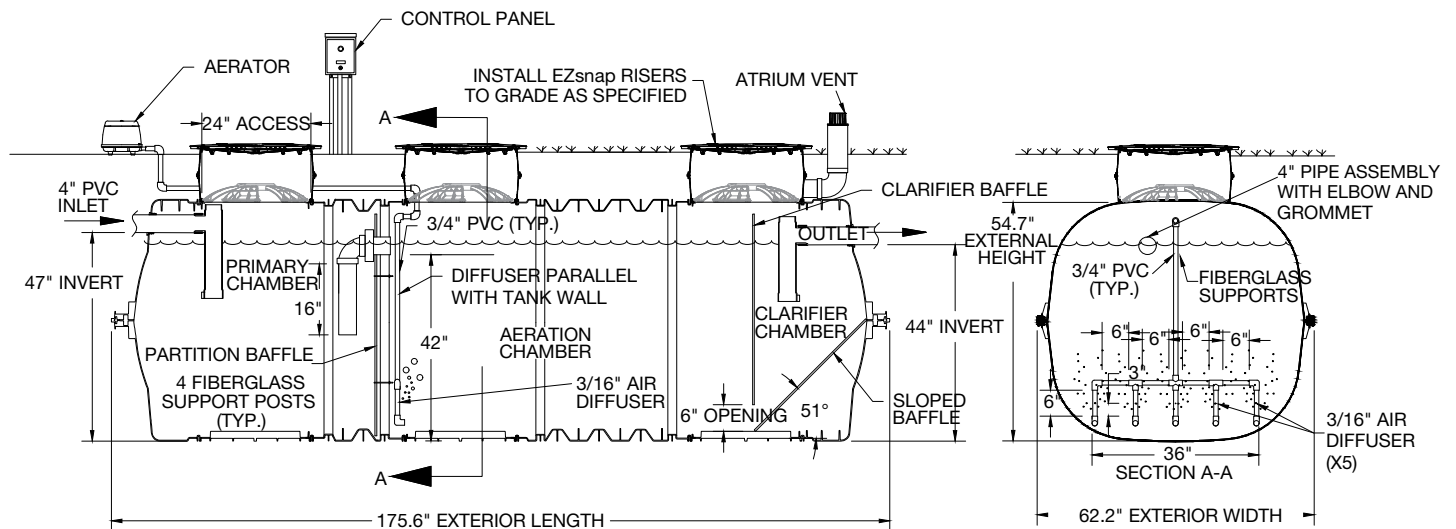

CP2305RI – SCHEMATIC

Setting High Level Pressure Switch

Bring plant to operating water level with compressor on.

Using properly sized screw driver, turn high level alarm adjustment screw clockwise until alarm occurs, then turn the screw counter-clockwise until alarm stops.

Part Number	Description
CL-100R	Light
BUZZER	Audible Alarm
5AMP BREAKER	Push to reset Circuit Breaker

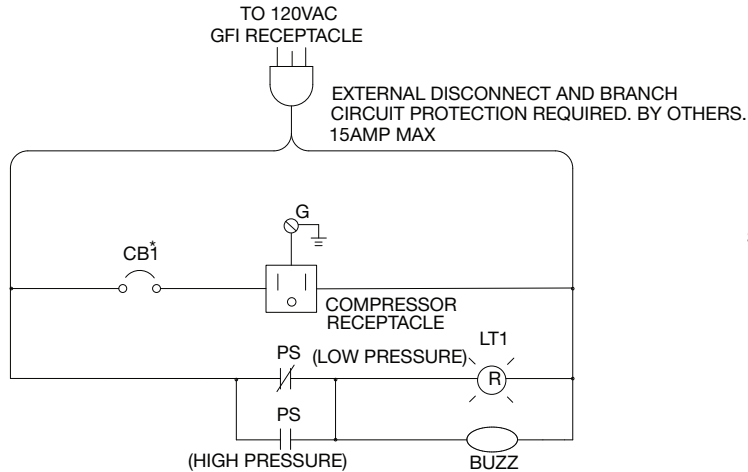

CP-2305R1

* SIZE VARIES WITH COMPRESSOR SIZE PER NATIONAL ELECTRICAL CODE

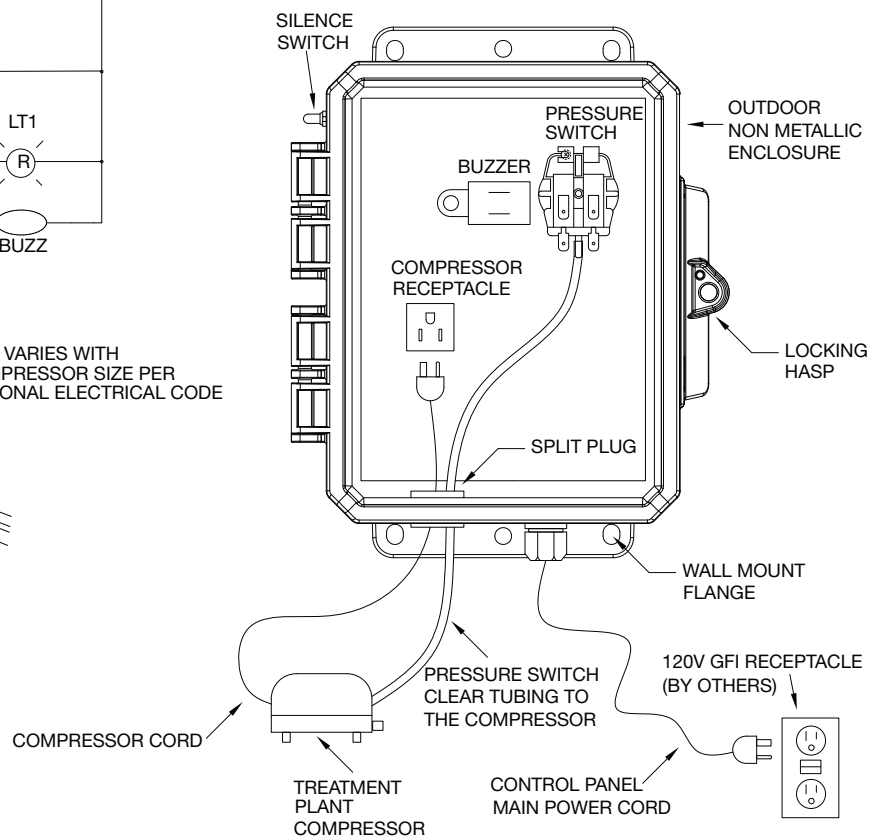
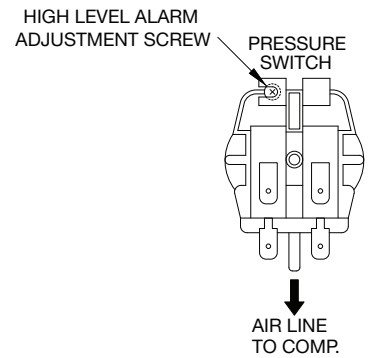
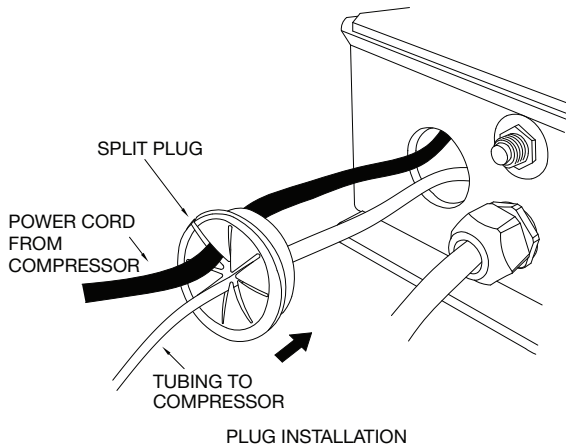

INSTALLER CHECKLIST

Owner: _____ Date of Inspection: _____

Mailing Address: _____

Model: _____ Model Serial No.: _____

System Address: _____ Lot # (if applicable): _____

Phone Number: _____ WW Permit No. (if applicable): _____

Designer/Engineer: _____ Contact Information _____

Authorized Installer: _____ Contact Information _____

Number of Bedrooms: _____ Number of Occupants: _____

Treated Effluent Dispersal Method: _____

Verify the following:

Treatment Unit

- NSF certification labels present (two locations)
- All treatment systems installed level
- All piping properly covered and compacted
- Ventilation intake(s) properly located and installed
- Treatment system filled with water (if water source available)
- Visually check aeration

Controls

- Proper wire size as per code
- Appropriate diagrams left in panel
- All electrical connections in panel are secure and correct connections used in junction box
- Panel wired per manufacturer's wiring diagram
- Control panel start-up procedures have been followed as per Installation Manual

Final Safety Inspection:

- Lid secured on all splice boxes
- All access risers in place and secure
- Access port covers secured
- Control panel on and set for automatic operation
- Control panel secured

Salcor 3G Ultraviolet Unit (if applicable)

- 3G Unit installed level
- Inlet & Outlet connection properly glued
- 4-inch riser pipe at proper level
- Disinfection sub-assembly properly installed
- Visually check flow
- Electrical wiring properly connected using correct wire nuts
- LED light inside junction box on when power is connected

Norweco Bio-Dynamic LF Unit (if applicable)

- LF Unit installed level
- Inlet and outlet connection properly glued
- Finished grade at least 6-inch below the top of riser
- Finished grade slopes away for surface drainage
- Feed tube filled and properly installed
- Treated effluent flows through tablet feeder
- Test the chemical application using chlorine test kit

Homeowner's Package (and manual) has been reviewed with homeowner by (check one):

- Installer Service Provider Dealer

SERVICE PROVIDER CHECKLIST

Owner: _____ Date of service call: _____
 System Address: _____ Lot # (if applicable): _____
 Mailing Address: _____ Model: _____
 _____ Model Serial No.: _____
 Phone Number: _____ WW Permit No. (if applicable): _____
 Service Provider: _____ Contact Information _____

Yes	No	Primary Tank	Yes	No	Discharge/Pump Tank (if present)
		Pump out required, sludge level ____ (in)			Pump out required, sludge level ____ (in)
		Air vents installed and operational			Air vents installed and operational
		Inspect basin/tank for infiltration and level			Inspect basin/tank for infiltration and level
Yes	No	Flow Equalization Tank (if present)			Floats operating and properly set
		Pump out required, sludge level ____ (in)			Pump verification (Manual/Automatic)
		Air vents installed and operational	Yes	No	Control Panel/Blower
		Inspect basin/tank for infiltration and level			Inspect controls and wiring
		Floats operating and properly set			Blower working, providing proper aeration
		Pump verification (Manual/ Automatic)			Alarm functioning properly
Yes	No	Treatment Tank			Timer settings are correct
		Pump out required, sludge level ____ (in)			Accessible and in good condition
		Air vents installed and operational			Air filter cleaned, dried and reinstalled
		Vigorous aeration in reactor box	Yes	No	Other
		Inspect media for proper biomass growth			Effluent Sample Taken, if applicable
		Inspect basin/tank for infiltration and level			Oil and grease deposits present
		Floats operating and properly set if present			Effluent filter cleaned and properly reinstalled, if applicable

Inspection of Effluent

Effluent odor: Earthy Musty Pungent Septic
 Effluent color: Brown Grey Cream Black Clear

Final Safety Inspection:

- Lid secured on all splice boxes
- All access risers in place and secure
- All access port covers in place and secured
- Control panel is set for automatic operation and secured

System Notes and Recommendations: _____

TREATMENT PLANT DATA PLATES

Data plates are affixed to the control panel and aerator. The serial numbers must match.

2"x4"

INTEGRATOR
water technologies

15785 Industry Way, Walker, LA 70785
1-800-219-9183

The ENVIRO-AIRE Series™
Model EA52.5
NSF/ANSI STD 40
525 GPD CLASS 1

Serial No. _____

NSF

3"x4"

INTEGRATOR
water technologies

15785 Industry Way, Walker, LA 70785
1-800-219-9183

ALARM MALFUNCTION ELECTRICAL PANEL

The ENVIRO-AIRE Series™
Model EA52.5
NSF/ANSI STD 40
525 GPD CLASS 1

Serial No. _____

NSF

1-7/8"x4" (optional)

15785 Industry Way, Walker, LA 70785
1-800-219-9183

The ENVIRO-AIRE Series™
Model EA52.5
NSF/ANSI STD 40
525 GPD CLASS 1

NSF

WARRANTY

INFILTRATOR WATER TECHNOLOGIES, LLC (“INFILTRATOR”) INFILTRATOR TWO (2) YEAR MATERIALS AND WORKMANSHIP LIMITED WARRANTY

- (a) This limited warranty is extended to the end user of a Infiltrator ECOPOD®, Infiltrator Whitewater, and Infiltrator ENVIRO-AIRE Series Advanced Wastewater Treatment System (the “Infiltrator Product”). A Infiltrator System manufactured by Infiltrator, when installed and operated in accordance with Infiltrator’s installation instructions and local regulation by a licensed installer, is warranted to you: (i) against defective materials and workmanship for two (2) years after installation. Infiltrator will, at its option, (i) repair the defective System or (ii) replace the defective materials. This Warranty does not cover any damage caused by flooding, abuse, unauthorized disassembly, improper wiring or overload protection. This Warrants does not cover any of the house wiring, plumbing, drainage or disposal systems
- (b) In order to exercise your warranty rights, you must notify Infiltrator in writing at its corporate headquarters in Old Saybrook, Connecticut within fifteen (15) days of the alleged defect. Infiltrator reserves the right to inspect the item to confirm that it is defective.
- (c) YOUR EXCLUSIVE REMEDY WITH RESPECT TO ANY AND ALL LOSSES OR DAMAGES RESULTING FROM ANY CAUSE WHATSOEVER SHALL BE SPECIFIED IN SUBPARAGRAPH (a) ABOVE. INFILTRATOR SHALL IN NO EVENT BE LIABLE FOR ANY CONSEQUENTIAL OR INCIDENTAL DAMAGES OF ANY KIND, HOWEVER OCCASIONED, WHETHER BY NEGLIGENCE OR OTHERWISE. SOME STATES DO NOT ALLOW THE EXCLUSION OR LIMITATION OF INCIDENTAL OR CONSEQUENTIAL DAMAGES, SO THIS LIMITATION OR EXCLUSION MAY NOT APPLY TO YOU. THIS WARRANTY GIVES YOU SPECIFIC LEGAL RIGHTS AND YOU MAY ALSO HAVE OTHER RIGHTS WHICH VARY FROM STATE TO STATE.
- (d) THIS LIMITED WARRANTY IS THE EXCLUSIVE WARRANTY GIVEN BY INFILTRATOR AND SUPERSEDES ANY PRIOR, CONTRARY, ADDITIONAL, OR SUBSEQUENT REPRESENTATIONS, WHETHER ORAL OR WRITTEN. INFILTRATOR DISCLAIMS AND EXCLUDES TO THE GREATEST EXTENT ALLOWED BY LAW ALL OTHER WARRANTIES, WHETHER EXPRESS OR IMPLIED, OR STATUTORY, INCLUDING ANY WARRANTY OF MERCHANTABILITY, FINESSE FOR A PARTICULAR PURPOSE AND ANY IMPLIED WARRANTIES OTHERWISE ARISING FROM COURSE OF DEALING, COURSE OF PERFORMANCE, OR USAGE OF TRADE. NO PERSON (INCLUDING ANY EMPLOYEE, AGENT, DEALER, OR REPRESENTATIVE) IS AUTHORIZED TO MAKE ANY REPRESENTATION OR WARRANTY CONCERNING THIS PRODUCT, EXCEPT TO REFER YOU TO THIS LIMITED WARRANTY. EXCEPT AS EXPRESSLY SET FORTH HEREIN, THIS WARRANTY IS NOT A WARRANTY OF FUTURE PERFORMANCE, BUT ONLY A WARRANTY TO REPAIR OR REPLACE DEFECTIVE COMPONENTS.
- (e) YOU MAY ASSIGN THIS LIMITED WARRANTY TO A SUBSEQUENT PURCHASER OF YOUR HOME.
- (f) NO REPRESENTATIVE OF INFILTRATOR HAS THE AUTHORITY TO CHANGE THIS LIMITED WARRANTY IN ANY MANNER WHATSOEVER, OR TO EXTEND THIS LIMITED WARRANTY BEYOND THE STATED TWO (2) YEAR TERM.
- (g) NO WARRANTY OF ANY KIND IS MADE WITH REGARD TO ANY PRODUCT, COMPONENTS, DEVICES, MEDIA OR TREATMENT UNITS WHICH ARE MANUFACTURED BY OTHERS AND ARE INSTALLED IN CONNECTION WITH THE ECOPOD® PRODUCT. USE OF THESE PRODUCTS ARE AT YOUR OWN RISK.

CONDITIONS AND EXCLUSIONS

There are certain conditions or applications over which Infiltrator has no control. Defects or problems as a result of such conditions or applications are not the responsibility of Infiltrator and are NOT covered under this warranty. They include failure to install the ECOPOD® Product in accordance with instructions or applicable regulatory requirements or guidance and altering the ECOPOD® Product contrary to the installation instructions.



INFILTRATOR
water technologies

4 Business Park Road
P.O. Box 768
Old Saybrook, CT 06475
(860) 577-7000 • Fax (860) 577-7001
(800) 221-4436
www.infiltratorwater.com
info@infiltratorwater.com

For U.S. Patents information visit www.infiltratorwater.com/patents. Other patents pending. Infiltrator, Quick4 and EZflow are registered trademarks of Infiltrator Water Technologies. Infiltrator Water Technologies is a wholly-owned subsidiary of Advanced Drainage Systems, Inc. (ADS).

IWTK4623 03/2024 © 2024 Infiltrator Water Technologies, LLC. Not responsible for any typographic errors. Printed in U.S.A.

Contact Infiltrator Water Technologies Technical Services Department at (800) 221-4436 or info@infiltratorwater.com