

March 2024



FIXED FILM WASTEWATER TREATMENT SYSTEM

INSTALLATION, OPERATION AND MAINTENANCE MANUAL



INFILTRATOR
water technologies

CM Team

Infiltrator Water Technologies
4 Business Park Road
P.O. Box 768
Old Saybrook, CT 06475-0768
(800) 221-4436
www.infiltratorwater.com
info@infiltratorwater.com



TABLE OF CONTENTS

Distributor and Homeowner Notes	2
ECOPOD-NR® and ECOPOD-NX® Treatment Systems Notice.....	3
Introduction.....	4
Homeowner Care and Instructions	4
Installation Instructions.....	8
Troubleshooting Guide	12
ECOPOD-NR and ECOPOD-NX Unit Specifications	13
Data Plates	16-17
Service Policy.....	18
Warranty	19

NOTE: To the installer: Please make sure you provide this manual to the owner of the equipment or to the responsible party who maintains the system.

DISTRIBUTOR AND HOMEOWNER NOTES

1. The Infiltrator Water Technologies' Model E50-NR and E50-NX have been tested by Gulf Coast Testing, LLC and conform to NSF/ANSI Standard 40 & 245, Class 1 effluent requirements.
2. State and/or local regulations govern the installation and use of individual Aerobic Wastewater Treatment Systems and must be complied with.

Consult your local Sanitarian/Regulatory Agency prior to installation.

HOMEOWNER RECORDS

S/N: _____ DATE OF INSTALLATION: _____

INSTALLED BY: _____

DISTRIBUTOR: _____

This booklet provides operations, installation and warranty information on the **TREATMENT PLANT ONLY**. Other components manuals, such as dosing equipment or drip irrigation, require additional operations and carry separate warranties. Be sure that you have all of the correct manuals for each of the component pieces in your system. Contact your installer or call (800) 221-4436.

ECOPOD-NR AND ECOPOD-NX TREATMENT SYSTEMS NOTICE

Post in a Service/Utility Area

ECOPOD-NR and ECOPOD-NX TREATMENT SYSTEMS NOTICE

This home is served by an Individual Wastewater Treatment System. This system will serve you well only if it is properly maintained. Your system is comprised of:

Location of your system:

Please do not build on, fill over, allow heavy traffic or allow water to stand over this area. Avoid using strong chemicals, sanitizers, cleaning fluids, etc., which will kill helpful bacteria in the system. You should also avoid flushing grease, food scraps, cigarette butts, sanitary napkins, and other inorganic waste down the drain.

Your system should be serviced semi-annually for the first two years and annually, or as required by state or local requirements, for the life of the system and pumped out as indicated by a measuring the sludge levels in the system. Your service technician can advise you on the process and if you need more frequent or additional service.

For assistance with information regarding servicing your systems or any other questions, contact Infiltrator Water Technologies at (800) 221-4436.

All of the details regarding system operation can be found in the homeowner's manual on pages 4-6 of this Installation, Operation and Maintenance Manual. If you did not receive a copy, call (800) 221-4436 and we will send you one.

Keep a Record of Service Below:

DATE	SERVICE PERFORMED	SERVICE TECHNICIAN

INTRODUCTION

THE INFILTRATOR AEROBIC WASTEWATER TREATMENT SYSTEM AND HOW IT WORKS

The ECOPOD-NR and ECOPOD-NX Fixed Film Wastewater Treatment System you have purchased produces high quality water suitable for various dispersal methods. It is used to enhance your on-site wastewater dispersal system. You can be proud that by purchasing your ECOPOD-NR and ECOPOD-NX system, with a minimum amount of maintenance, you can directly contribute to a cleaner, safer environment.

All wastewater treatment systems of this type work by using bacteria that nature provides. By pumping air into the system, aerobic bacteria grow and thrive in large numbers. This population of bacteria speeds up the process of breaking down domestic wastewater, making it safer to release into the environment. This entire process takes place within the walls of your specially designed ECOPOD-NR and ECOPOD-NX Fixed Film Wastewater Treatment System. The result of this process is a clear, odorless discharge.

By following a few simple steps that you will find in this manual, your ECOPOD-NR and ECOPOD-NX Fixed Film Wastewater Treatment System will provide you with years of service and the knowledge that you are doing your part to protect public health and our groundwater, lakes, rivers, and streams.

The ECOPOD-NR and ECOPOD-NX Fixed Film Wastewater Treatment System may be only one of several components required by your health department to provide a complete on-site system.

PROCESS DESCRIPTION

The ECOPOD-NR and ECOPOD-NX Fixed Film Wastewater Treatment Systems are devices that house an engineered plastic media specifically designed to treat domestic wastewater. There are no moving mechanical parts or filters in the chamber or tank that houses the ECOPOD-NR and ECOPOD-NX.

Wastewater first enters a pretreatment/settling tank or chamber similar to a conventional septic tank. In this tank or chamber, debris and settleable solids settle to the bottom and are decomposed by anaerobic bacteria. The clarified wastewater then enters the ECOPOD-NR or ECOPOD-NX, which is submerged in a separate chamber or tank, where it is introduced into an oxygen rich environment. An external aerator is connected to the ECOPOD-NR or ECOPOD-NX and provides the necessary air to the system. In this oxygen rich environment, a colony of bacteria, called the biomass, develops and is capable of digesting (breaking down) biodegradable waste. This is a continuous process as the biomass is supplied with incoming wastewater and oxygen. The aerator is also used to create an airlift in the ECOPOD-NR and ECOPOD-NX that recirculates flow back to the pretreatment tank or chamber.

In this system conditions are more favorable to attached growth bacteria. This means that the most common disadvantages of other types of systems such as accumulating settled sludge, floating sludge, and washouts are greatly reduced or eliminated. In addition to organic molecules that impose a biochemical oxygen demand (BOD) and total suspended solids (TSS) entering the system, ammonia nitrogen is also a component of domestic

wastewater that significantly reduces water quality. Nitrification of the ammonia and denitrification of nitrates occur within the ECOPOD-NR and ECOPOD-NX system. The recirculation from the airlift is used to achieve increased total Nitrogen reduction.

HOMEOWNER CARE AND OPERATION INSTRUCTIONS

The ECOPOD-NR and ECOPOD-NX Fixed Film Wastewater Treatment System has been designed and built to provide long term, reliable and efficient service. Once the unit has been installed (see installation instructions), the unit will operate with a minimum amount of attention.

Please reference the system's Data Plates that are located on the aerator and the alarm panel in the event that a problem arises or service is required.

The following should be performed as checks for system functioning:

Daily

- Observe the warning device, which comes on when the power to the aerator has been interrupted, the air supply system has malfunctioned, or there is a high water level in the treatment plant. If the alarm is activated, check for a blown fuse or thrown circuit breaker. Check the aerator to be sure it is operating. Once accustomed to the soft humming sound of a properly operating unit, any unusual noise is an indication of malfunction. If an unusual noise is detected or total failure is observed, call an authorized Infiltrator service provider or dealer/distributor.

Weekly

- Check the treatment plant for offensive odor. If such a condition should develop, call an authorized Infiltrator service provider or dealer/distributor.

Ongoing Maintenance and Care

Every Six Months for First Two Years After Installation (Annually or as required by state or local requirements thereafter the initial two years. Performed by a certified service provider.)

- Ensure no flow is coming from the home during the following maintenance procedure. Before turning off power to the aerator, open the pretreatment tank or chamber lid and check to ensure water is flowing through the primary return assembly; location shown below.



IM-540



IM-1530 First Compartment

Once confirmed, open breaker to aerator and proceed as appropriate.

INTRODUCTION

- Inspect and make any necessary adjustments to mechanical and electrical components, including the control panel.
- Inspect the air filter on the aerator. Rinse with warm water and allow filter to dry completely before reinstalling or replace if necessary. (See installation instructions.) Do not use oil or other solvents.
- Inspect effluent quality's color, turbidity and check for odor.
- Take a sample from the reactor tank or chamber to check the sludge level described in the "Solids Removal" section.
- The homeowner must be notified in writing if any improper operation is observed and cannot be corrected at the time of service.

THE FOLLOWING CAN NEGATIVELY IMPACT THE TREATMENT PERFORMANCE OF YOUR SYSTEM. TO KEEP MAINTENANCE TO A MINIMUM AND ENSURE HIGH QUALITY EFFLUENT, IT IS STRONGLY RECOMMENDED THAT THE FOLLOWING ARE NOT DISCARDED INTO YOUR SYSTEM:

- Greases, fats, or oils
- Pesticides, herbicides, or any other toxins
- Paints, household chemicals, automobile fluids or mop water
- Non-biodegradable items such as cigarette butts, rags, feminine hygiene products, disposable diapers, condoms, hair, bandages, coffee grounds, paper towels, plastic or metallic objects, etc.
- Citrus products, oranges, lemons, grapefruit, etc.
- Septic system additives as they may do more harm than good
- Hydraulic overload due to excessive water use or inflow from other sources such as rain gutters
- Home brewery waste, strong medicines, and antibiotics.
- Strong disinfectants
- Discharge from water softeners
- Antibacterial soaps and excessive amounts of bleach should be avoided

The following practices will increase the intervals between maintenance/service calls:

- Recommended detergents are powdered, low-sudsing, low phosphates and biodegradable. Fabric softener dryer sheets are recommended rather than using liquid fabric softeners.
- Use non-chlorine, biodegradable and non-toxic cleaning products such as baking soda.
- Use garbage disposals sparingly. Dispose of food waste, grease, etc., in the solid waste bin. Food waste represents additional matter your Wastewater Treatment System will have to digest, increasing pump-out intervals.
- Laundry loads should be spread out over the week. Multiple loads on one day or half loads are not recommended.

SYSTEMS REQUIRING PUMPOUTS DUE TO THE ABOVE

VIOLATIONS ARE NOT COVERED BY THE WARRANTY.

The ECOPOD-NR and ECOPOD-NX Wastewater Treatment Systems are designed to handle domestic wastewater from a typical residential home; nothing else should go into them. For anything other than domestic wastewater, contact Infiltrator Water Technologies.

SAFETY WARNINGS

The proper operation of this or any other home sewage system depends upon proper organic loading and the life of the microorganisms inside the system. Infiltrator is not responsible for the in-field operation of a system, other than the mechanical and structural workings of the plant itself. Infiltrator Water Technologies cannot control the amount of harsh chemicals or other harmful substances that may be discharged into the system by the occupants of a household; we can only provide a comprehensive owner's manual that outlines substances that should be kept out of the system.

Hydraulic overloading (flows in excess of design flow) may cause the sewage treatment system not to perform to the fullest capabilities.

Ants have been shown to be destructive to the aerator. Regular care should be taken to prevent infestation of ants near the system. Damage or destruction by ants is not covered under manufacturer's warranty.

Your state or local health department may require other pieces of equipment to function separately or in conjunction with equipment manufactured by Infiltrator Water Technologies. Infiltrator Water Technologies is not responsible for the mechanical or electrical safety of equipment it does not manufacture or supply with its fixed film wastewater treatment system. Care should be used in evaluating the electrical or mechanical safety of equipment manufactured by others. This may include but is not limited to electrical control panels or aerators. If electrical service has not been installed for checking air distribution system during installation, and if an extension cord is used to test the aerator, never leave the extension cord plugged in. Remove it after testing is completed.

DUE TO A POSSIBLE FIRE HAZARD, DO NOT PLUG INTO SERVICE EQUIPMENT ON POWER POLE AND DO NOT USE EXTENSION CORDS. ALL ELECTRICAL WORK PERFORMED BY THE INSTALLER OR OTHERS MUST BE IN ACCORDANCE WITH THE NATIONAL ELECTRICAL CODE AND LOCAL CODES.

SOLIDS REMOVAL

Determination of the need for solids removal can be done with a sludge judge sample. The sludge judge should be used to gauge the sludge layer thickness along either side of the ECOPOD reactor as accessible through the first riser near the reactor tank or chamber inlet. Several samples should be taken in this vicinity, and if the highest recorded value for the sludge layer is greater than 12 inches, contact your local authorized sewage disposal service to have the tank contents pumped out and disposed of properly.

INTRODUCTION

Pumping Method

- The aerator should be in the off position.
- Remove all of the solids from both the reactor tank or chamber and pretreatment tank or chamber.
- After the pump out process is complete, fill the reactor tank or chamber with fresh water to normal operating level.
- Refer to the “Installation Procedure” to get the treatment plant back into operation.
- Should indication of improper operation be observed at any time, contact your local authorized Infiltrator dealer/distributor.

NOTE: THE COST ASSOCIATED WITH PUMPING THE TREATMENT SYSTEM IS NOT COVERED UNDER WARRANTY AND IS NOT INCLUDED IN THE SERVICE POLICY.

SEASONAL USE GUIDELINES OF ECOPOD-NR and ECOPOD-NX

These guidelines are for conditions as outlined below and apply for systems that are not in use for periods of time indicated. Site conditions not covered by the following must be forwarded to Infiltrator for recommended guidelines to meet the particular site conditions.

1. System not in use for more than one month and less than three months. Electrical power is left on and there are no frost conditions.
 - Leave aerator on.
 - Leave system running.
2. System not in use more than three months. Electrical power is turned off and there are no frost conditions.
 - Remove all materials and liquid from tank or chamber.
 - Refill with clean water.
 - Turn off aerator.
3. System not in use more than three months. Electrical power is on and there are no frost conditions.
 - Leave aerator on and system running; OR
 - Remove all material and liquid from tank or chamber.
 - Refill with clean water.
4. System not in use. Electrical power is turned off and there are frost conditions.
 - Remove all material and liquid from tank or chamber.
 - Turn off aerator.
 - If high groundwater is present, fill with clean water.
 - If no groundwater is present, leave tank empty.

UNDER NO CIRCUMSTANCES SHOULD THE AERATOR BE TURNED OFF FOR MORE THAN A FEW DAYS WITHOUT REMOVING TANK CONTENTS

SAMPLING

Figure 1

ECOPOD E50-NR or E50-NX in an IM or CM-1060

A	PRETREATMENT TANK/CHAMBER
B	REACTOR TANK/ CHAMBER
C	ECOPOD REACTOR
D	RECIRCULATION LINE
E	ACCESS
F	CONTROL PANEL
G	AERATOR
H*	VENT**
I*	EFFLUENT SAMPLE PORT**
J	OUTLET

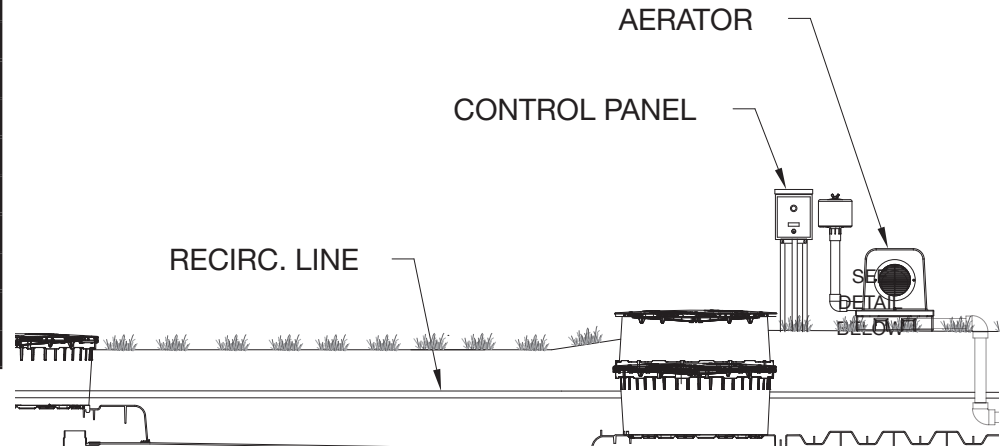

*Only one needs to be used.

**All vent samples port configurations can be used with the IM-1060, CM-1060 and IM-1530 tanks. The vent through the riser can not be used with 6-inch risers as shown in the IM-1530 illustration. One of the alternative vent and sample port options must be used instead.

E50-NX in a two-compartment IM-1530

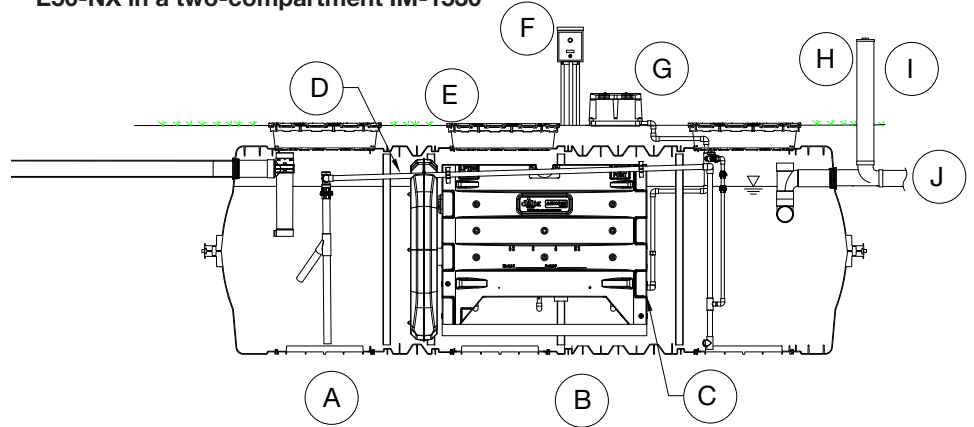

Sample Procedures (If Applicable):

1. Prior to collecting samples, contact the certified testing laboratory to request the appropriate sample containers.
2. Collect, handle, store, and transport samples as as specified by the testing laboratory requirements and procedures.
3. Samples should be taken from the effluent discharge line or from the effluent pump tank or after the disinfection device.
4. Induce flow through the system by turning water faucets on, flushing toilets or by inserting a garden hose fitted with a backflow prevention device inserted into the inlet tee or access riser positioned upstream of the reactor. If a garden hose is used, ensure the end of the hose is not submerged in the wastewater. Allow the water to run for a minimum of four minutes before taking the sample. This will allow any solids to be flushed out that might have accumulated in the discharge pipe. Please see Figure 1 for reference.
5. Insert sample container to collect only effluent that is flowing over the cascading edge.

If these methods cannot be used or a sample port is not accessible, please contact Infiltrator Water Technologies for additional information.

Alternative vent and sample port options.

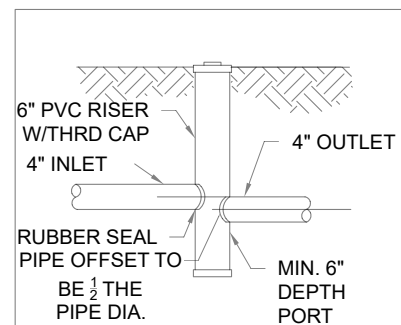
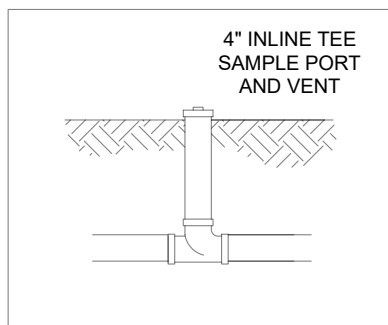
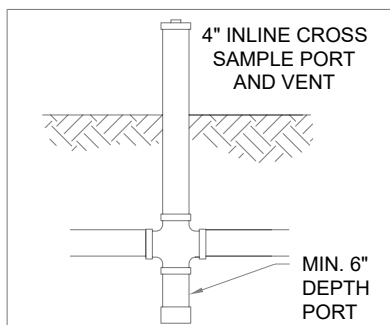

INSTALLATION INSTRUCTIONS

ONLY FOR USE BY CERTIFIED, LICENSED INSTALLERS

1. Tank Delivery and Handling

Care must be taken offloading and unpacking tank and components. Care must be taken not to damage tank and components with forklift or any other offloading device. Check for damaged tank and components that may have occurred in transportation and notify factory or distributor within 24 hours of delivery.

2. Set and Backfill Tanks

Note: For the ECOPOD-NX in IM-1530, only the IM-1530 needs to be set and backfilled. An ECOPOD-NR and ECOPOD-NX installed in IM-1060 or CM-1060 will require a pretreatment tank.

An ECOPOD-NR and ECOPOD-NX Treatment System will require a pretreatment tank or chamber. Depending on the supplier it may be integrated into a single tank or require setting a separate tank. Proper fall between tanks is required and is specified by local regulatory code requirements. Excavate and set tank as recommended by the tank manufacturer. Prior to backfill, install tank access risers as needed. It is very important to follow all backfill and compaction procedures required by the tank manufacturer.

Note: It is recommended that any excavation be roped off with caution tape for jobsite safety.

Figure 2

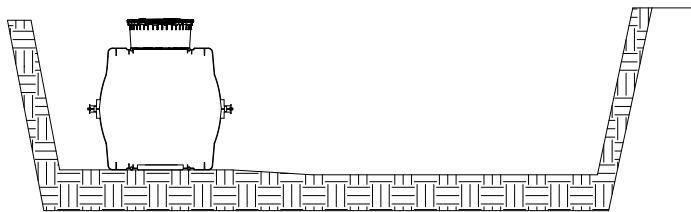
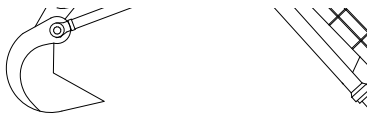
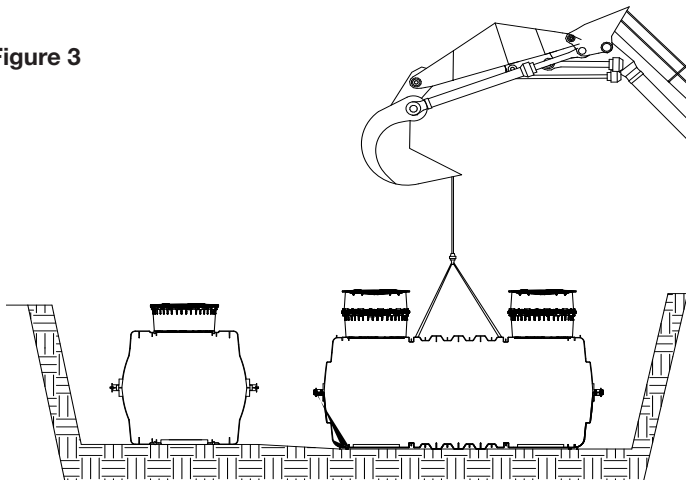
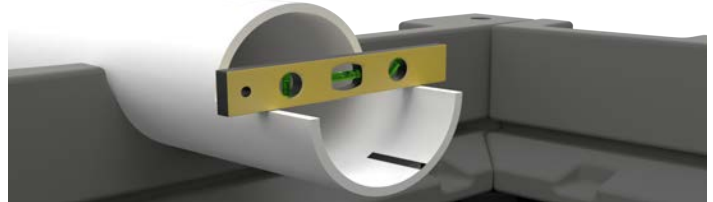

Figure 3



3. Plumb Tank Inlets and Outlets

Plumb and solvent weld all inlet and outlet tee(s) and piping on the pretreatment tank (if applicable) and reactor tank to the inlet and outlet piping and tee(s). The pretreatment tank plumbing requirements are specified by local regulatory code. For the ECOPOD-NR and ECOPOD-NX in the IM-1060 or CM-1060, install a 4-inch pipe through the reactor tank inlet, connect the 4-inch reactor box pipe (supplied) using a 4-inch coupler such that the 4-inch reactor box pipe extends approximately 6 to 8 inches past the ECOPOD-NR and ECOPOD-NX reactor box inlet saddle as shown. Using a level across the flats as shown below, ensure the 4-inch reactor box pipe is reasonably level before solvent welding the connections.



The reactor tank outlet tee assembly should be solvent welded to the outlet pipe and must extend six to twelve inches into the outlet side of the tank. The reactor tank inlet piping should be sloped downward toward the ECOPOD media and the outlet piping should sloped downward and away from the tank.

4. Plumb Air Distribution System (E50-NR or E50-NX in IM-1060 or CM-1060 only)

Note: For the ECOPOD E50-NX in IM-1530, the only air distribution plumbing will involve connecting the air grid assembly extension to the aerator line. The installation will be the same as in the ECOPOD E50-NR and ECOPOD E50-NX installation instructions below.

Remove the Air Lift Assembly from the box.

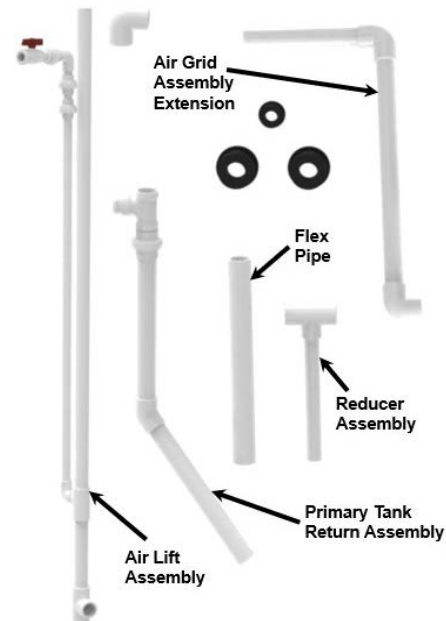

Note: Solvent weld the following connections only after determining the length needed for each section and placement of the aerator and recirculation line.

INSTALLATION INSTRUCTIONS

Access the vertical pipe at the outlet end of the ECOPOD reactor box through the access port on the outlet end of the tank. Attach the air grid extension to the upper end of the air grid piping, both labeled "A".



Place the Air Lift Assembly in the tank through the outlet end port. Ensure the Air Lift Assembly is placed on the floor of the tank and is not sitting on top of a rib. The elbow connected to the bottom of the Air Lift Assembly must be directed toward the ECOPOD reactor box.

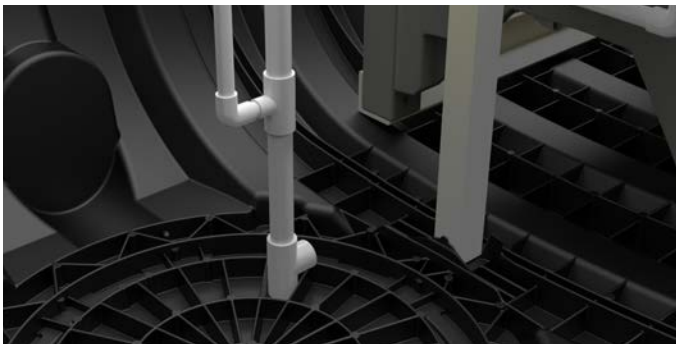

Attach the Reducer Assembly to the Air Grid Extension as shown below matching the ends labeled "B".

Loosen the bottom union of the air lift assembly and rotate top to connect to the reducer assembly. **WARNING: ENSURE ONLY THE BOTTOM UNION IS LOOSENED.** Orient the assemblies in such a way to accommodate the airline that will come in from the aerator and the recirculation line that will go back to the pretreatment tank.

The end of the Reducer Assembly and height of the Air Grid Extension may be cut as needed on site to facilitate assembly to the air lift assembly matching ends labeled "C".

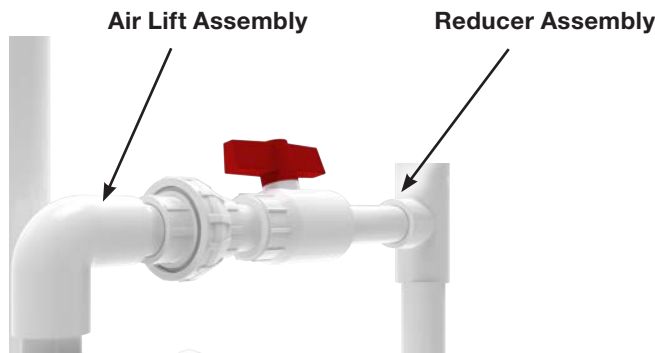

Hand tighten the union shown by the red arrow in the following graphic until secure.

NOTE: Identify the location of the aerator and placement of the Recirculation Line prior to cutting holes in the riser.

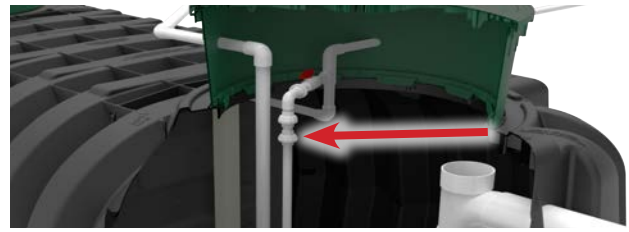

Orientation of recirculation line will be dependent upon site conditions. Place the 90 degree elbow (provided) on the Air Lift Assembly ("D" to "D" labels) positioned facing in the direction of the desired location of the recirculation line back to the pretreatment tank. Install risers. Using a 1 $\frac{3}{4}$ -inch hole saw, drill a hole in the riser of the outlet end of the reactor tank aligned with the 90 degree elbow ensuring it is high enough to account for the required fall of the recirculation line back to the pretreatment tank. The maximum height of the circulation pipe shall be 9 inches above the tank. Insert the 1" PVC grommet into the hole. Insert 1-inch Flex Pipe (provided) through the grommet and connect to the 90 degree elbow as shown (connections are labeled "E").

After ensuring the correct placement or position of all components, solvent weld all connections.

Mark hole location in pretreatment tank riser to ensure the recirculation line achieves a fall of at least 1/8 inches per 1 foot of pipe as it travels from the reactor tank riser back to the pretreatment tank riser. Use a 1 $\frac{3}{4}$ -inch hole saw to drill a hole in the riser of the pretreatment tank. Insert the 1-inch PVC grommet into the hole. Insert 1-inch Schedule 40 PVC through the grommet.

Install fittings and additional 1-inch Schedule 40 piping around forward reactor tank riser until the line has reached the pretreatment tank riser. Solvent weld the recirculation line from the reactor tank to the pretreatment tank.

Install and connect to the Pretreatment tank Return Assembly. Loosen the union connection on the Pretreatment tank Return Assembly just below the tee. Rotate the bottom portion as needed so the pipe outlet is pointed towards the tank inlet. Tighten the union. See picture below.

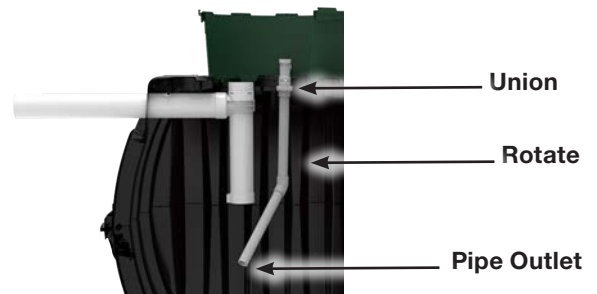

INSTALLATION INSTRUCTIONS

Warning: Deviation from required slope of the recirculation line will change the performance of the system. Breaking or removing the red seal around the Airlift ball valve without authorization from Infiltrator Water Technologies will void the system warranty.

5. Backfill Treatment System

It is very important to follow all backfill and compaction procedures required by the tank manufacturer. Backfill the treatment system in lifts of no more than 12 inches. Compact each lift up to the treatment system inlet and outlet pipes. Reference the Infiltrator IM- and CM-Series Tank Installation Instructions.

6. Fill Reactor Tank with Clean Water

Begin filling the reactor tank or chamber with clean water while the air distribution and control panel assembly are completed. Continue filling the tank or chamber until water level reaches the outlet tee. It will take several hours using residential water service.

7. Aerator Placement and Connection

Do not install the aerator(s) in a low-lying area where water may accumulate. The aerator should be installed near the control panel and within 100 feet of the reactor tank or chamber. The aerator can be installed outdoors or in a clean, well ventilated area, such as a tool room, garage, etc.

At the aerator, connect the 1-inch galvanized male adapter to the aerator using the supplied hose and clamps. Next connect the aerator to the air supply lines using either a 3/4- or 1-inch adapter or a 2- or 1-inch adapter and solvent weld all fittings. See pictures below.



Drill a hole in the riser to accommodate the 3/4-inch grommet for the airline, taking into account where the aerator will be located. Extend piping up from the reducer tee and through the grommet towards the aerator. If the distance to the aerator exceeds 60 feet, expand the 3/4-inch schedule 40 PVC from the riser to 2-inch schedule 40 PVC for the remainder of the distance for a maximum distance of 100 feet. Please note the schedule 40 PVC must be 3/4 inch for the 60 feet from the riser and the 2-inch schedule 40 PVC will begin 60 feet from the riser.

A minimum of 12 inches of ground cover is recommended over the air supply piping.

8. Install the Vent

Use a 5-inch hole saw to drill a hole in the side of the riser. Insert a 4-inch PVC grommet into the hole. Insert 4-inch Schedule 40 PVC through the grommet. Solvent weld a 90 degree elbow pointing upward. Insert 4-inch Schedule 40 PVC into the 90 degree elbow and extend above existing grade. Place the Atrium vent onto the 4-inch Schedule 40 PVC for proper ventilation.

9. Mounting Control Panel



Mount the control panel in a location such that the alarm can be heard and be readily observed. The control panel must be connected to a 20-amp maximum electrical source equipped with a ground fault interrupter (GFI) circuit breaker. Install a power disconnect switch to the panel that is operable and available to a maintenance provider. The control panel must be grounded. Connect the source ground wire to the ground location in the panel. All electrical work shall be done according to NEC and local code requirements.

- A. Attach control panel to a suitable mounting surface. Use appropriate screws for all four mounting holes on the back of the enclosure.
- B. The control panel contains a fuse or circuit breaker for the aerator. An electrical malfunction in the aerator, or wiring to the aerator, will cause the fuse or circuit breaker to blow. The control panel also contains a pressure switch and visual and audible alarms. Loss of air pressure caused by aerator system malfunction, or a high-water level in the treatment tank, will cause the alarm to sound and light to illuminate.
- C. Control panel is rated for outdoor service. However, do not place it where it can be immersed in rising water or where runoff water such as from a roof will pour onto it. Do not mount it where it is subject to wetting from sprinklers, hoses, etc.
- D. Connect conduit. After the control panel is properly mounted, connect conduit and install wiring as shown on drawings bound herein (Schematics).
- E. Connect the pressure air tubing to the 1/8-inch barb-fitting in the air piping system. The air tubing should be protected by conduit as shown on the drawing.

INSTALLATION INSTRUCTIONS (CONT.) & TROUBLESHOOTING GUIDE

10. System Startup

Ensure breaker to the Aerator is open. Provide power to the control panel. Provide clean water to the pre-treatment and treatment tanks. Once the tank water level reaches the outlet in the treatment tank, close breaker to the Aerator. Aerator should start. See additional steps below.

- A. Check if water is flowing continuously from 4-inch line over ECOPOD reactor box and touching the flow indicators. If no flow or if the flow is not touching the flow indicator lines:
 - Check if aerator is running
 - Check if air supply plumbing is leaking
 - Contact Infiltrator
- B. Check to ensure water level is approximately 5 inches +/- 1/4 inch below the top of the ECOPOD reactor box. If water level is at a different height:
 - Check if tank is not level
 - Check if outlet pipe is not drilled at right height
 - Check for clog in inlet/outlet pipe
- C. Set the high-level pressure switch. To set the high-level pressure switch that detects high water level in the unit bring the tank to operating water level with aerator turned on. Using properly sized screwdriver turn high level alarm adjustment screw clockwise until alarm occurs. Then turn the screw counterclockwise until alarm stops.
- D. Check air piping joints for leakage using a soapy water solution. Repair if necessary and then carefully backfill air distribution piping and tanks.
- E. Finish grade the site. Divert surface water away from the system and install or plant ground cover to prevent erosion.
- F. Tank is ready to receive incoming sewage. No special start-up procedures are required. The process is naturally occurring and does not require any special additives.
- G. Replace and secure all tank access lids. Close up the enclosure door on control panel and lock if necessary.
- H. Spend time with your customer whenever possible. Review operation instructions. Be sure that the customer has a manual to keep. This saves valuable time avoiding return visits.

WARNING: CONTROL PANEL CONTAINS HIGH VOLTAGE

TROUBLESHOOTING GUIDE

Air Supply Malfunction

1. Check to be sure air distribution is working properly. This will be evident in the reactor as the liquid will be forcefully agitated. A septic (rotten egg) odor could mean that the system is not getting enough air. If the air system is not working, partially working or working very little (slight bubbles), check the following:
 - A. Check to be sure the aerator is working.
 - Check timer if one is used.
 - Bypass timer temporarily and connect directly to source.

- Check the electrical source.
- If electrical source is okay, check service guide on aerator for troubleshooting information.
- Wash air filter on aerator. Allow filter to dry completely before reinstalling.
- Consult manufacturer for servicing information.

- B. Check to be sure tank is not severely out of level. Air follows a path of least resistance. The pressure differences can be enough to restrict air flow.
- C. Check for broken or cracked air lines both outside and inside the tank.
- D. Ants will cause the aerator to malfunction. Check to see if there is an ant nest around the aerator.
- E. Aerator should be protected from rising water.
- F. Always check to see if inlet and outlet lines are correctly installed.

Internal Assembly Malfunction

1. Check to be sure all internal piping and connections are tight.

Design Overload

1. The system could be hydraulically overloaded (there is too much water going through the system for the size of the system).
2. The system could be biologically overloaded (there is too much waste for the size of the system).
3. Discuss usage with the homeowner.

Improper Installation or Settling

1. You should follow the manufacturer's installation procedures very carefully.
2. Where settling is common, approximately 2 inches of a well graded bedding material should be placed and tamped in the bottom of the hole.
3. Proper installation is the first step in preventing callbacks for service problems.
4. Whenever possible, it is important to spend time with the homeowner. Be sure they have an Installation, Operation and Maintenance Manual. A few minutes invested in the beginning will avoid service calls later.

No Harsh Chemicals Should Be Put into the System

1. Water in the reactor tank or chamber should be relatively clear in both the reactor and quiescent zones. Blue or gray/blue water indicates heavy use of detergents or other chemicals. If water appears sudsy there is too much detergent being used.
2. Water in the quiescent zone should be clear. Water is discharged into the discharge tee at a minimum of 6 to 8 inches below water surface. You MAY NOT be able to see clear water by looking into the tank. See Sampling section for instructions to collect a sample.

TROUBLESHOOTING GUIDE

3. Oils and grease should be kept to a minimum. Grease tends to form in white balls.

Troubleshooting Electrical System

1. Aerator does not run:
 - A. Check main service for power.
 - B. Check and/or replace fuse with same rating as in control panel.
2. Alarm does not occur when aerator is off:
 - A. Malfunctioning pressure switch – reset or replace.
 - B. Malfunctioning light or buzzer – replace.
3. Alarm occurs continuously even when aerator is running:
 - A. Air leak in main air system or air tubing to pressure switch – repair leak or replace air line.
 - B. Malfunctioning pressure switch – reset or replace.
 - C. High water level in tank – inspect for cause.
 - D. Short in float switch wire or float switches – repair or replace.

Component Replacement Procedure

- **Aerator:** Follow the same procedure as outlined in the “Installation Instructions”.
- **Pressure Switch (if applicable):** Turn all power off to the control panel. Remove control panel mounting. Remove screws securing pressure switch as well as connectors and tubing. Reverse procedure to install new pressure switch.
- **Audible Alarm:** Turn all power off to the control panel. Remove screw attaching alarm to panel as well as connectors. Reverse procedure to install new alarm.
- **Alarm Light Holder:** Turn all power off to control panel. Remove lock nut securing light holder as well as connectors. Remove lamp holder. Install new light holder with gaskets furnished. Continue with reverse procedure.
- **Alarm Light Bulb:** Turn all power off to control panel. Remove red light cover. Remove and replace bulb, which is a push-in type. Replace light cover and cover gasket.
- **Circuit Breaker:** Turn all power off to control panel. Remove fasteners securing circuit breakers as well as connectors. Replace circuit breaker with fasteners and restore power to the control panel.

NOTE: ALL REPLACEMENT PARTS ARE AVAILABLE FROM YOUR LOCAL DISTRIBUTOR.

CAUTION: ELECTRICAL SHOCK OR HAZARD MAY

OCCUR IF UNIT IS NOT SERVICED PROPERLY. THE MANUFACTURER RECOMMENDS THAT A LICENSED ELECTRICIAN BE CALLED WHEN ELECTRICAL PROBLEMS OCCUR.

GENERAL COMMENTS

1. Only factory approved equipment can be used for replacement on individual treatment systems.
2. If the decision is made to pump out a system, be sure to contact a licensed waste hauler.
3. If a chronic problem develops and all items have been checked, contact Infiltrator.
4. Taking pictures of systems when troubleshooting will help document activity in the field.
5. Keep good records.

SPECIFICATIONS

ECOPOD-NR and ECOPOD-NX Unit Specifications

Treatment Plant	Treatment Capacity (GPD)	Minimum Pretreatment Tank or Chamber Total Volume (Gal)	Reactor Tank or Chamber Volume (Gal)
E50-NR	500	475	1,094
E50-NX	500	475	1,094 (1,062 for E50-NX in IM-1530)

MATERIALS OF CONSTRUCTION

Suffix CA	Reactor Tank	Concrete
	Media Container	Polyethylene
Suffix IM	Reactor Tank	Polypropylene
	Media Container	Polyethylene
Suffix CM	Reactor Tank	Polypropylene
	Media Container	Polyethylene

These are standard production units. Other configurations are available upon request.

ECOPOD-NR and ECOPOD-NX Electrical Requirements

Model	Aerator	Motor Full Load Amps	Measured Operating Watts	Electrical Requirements
E50-NR	LW-250	3.5	185	115 volt – single phase
E50-NX	LW-250	3.5	185	115 volt – single phase

CP2210R2 SCHEMATIC

CP2210R2

Setting High Level Pressure Switch

Bring plant to operating water level with compressor on. Using properly sized screw driver, turn high level alarm adjustment screw clockwise until alarm occurs, then turn the screw counter-clockwise until alarm stops.

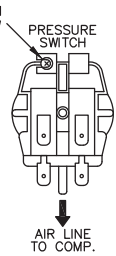

EXTERNAL WIRING

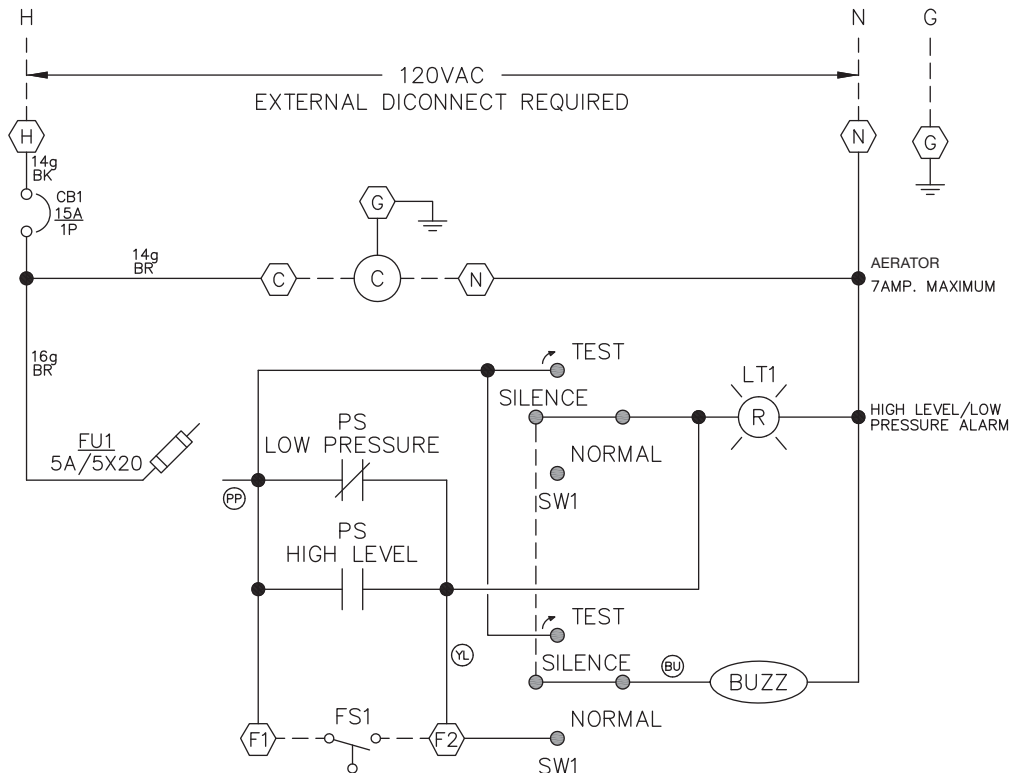
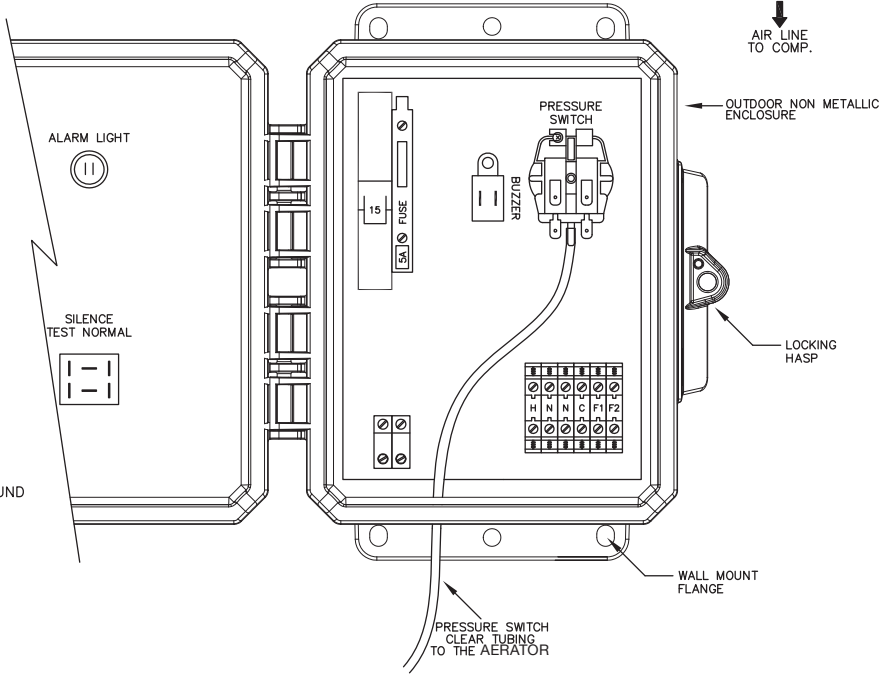
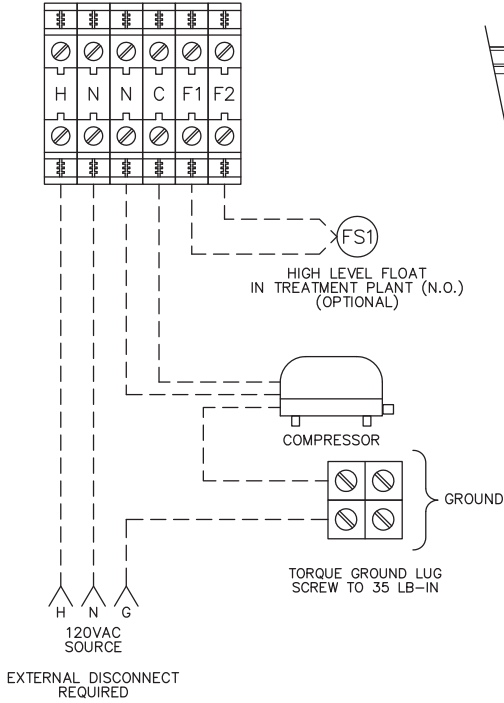

FS1 - H.L. FLOAT SWITCH. IN TREATMENT PLANT (IF REQ'D)



Twin Drive Linear Pump Model LW-250

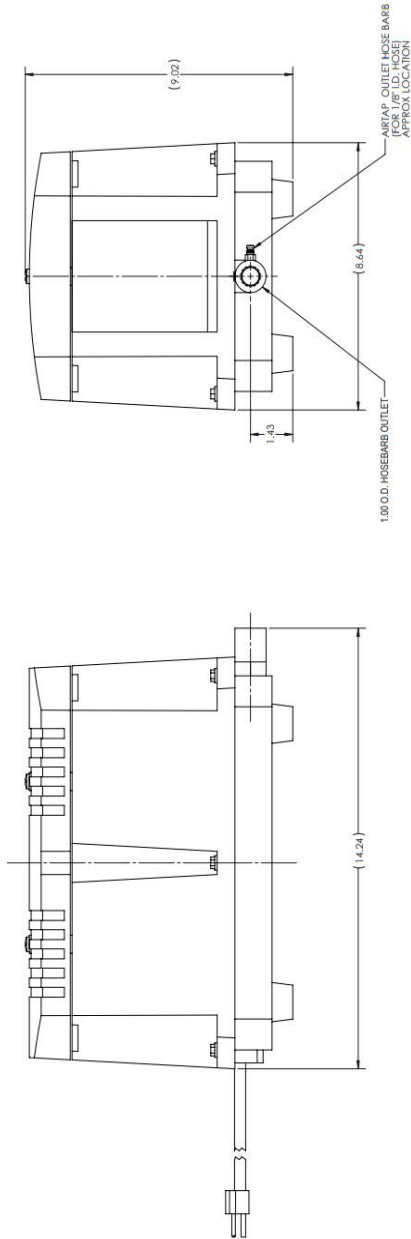

Performance Table

Voltage : 115V Pressure : 2.9 PSI (Pressure Range : 1.45~5.8 PSI)

Pressure(PSI)	1.45	2.9	5.8
Flow (CFM)	10.56	9.15	4.77

Pressure(PSI)	1.45	2.9	5.8
Current (A)	4.37	3.82	2.62

Pressure(PSI)	1.45	2.9	5.8
Input (W)	291	275	173

Pressure(PSI)	1.45	2.9	5.8
Sound Level (dB/A)		42.7	

Spec

Spec	Drive Unit Voltage (V)	Frequency (Hz)	Input (W)	Working Pressure Range (PSI)	Rated Pressure (PSI)	Rated Air Flow (cfm)	Connecting Pipe (in)	Weight (lb)
Model	Single Phase 115	60	275	1.45~3.63	2.900	8.63	φ1.00	31.1

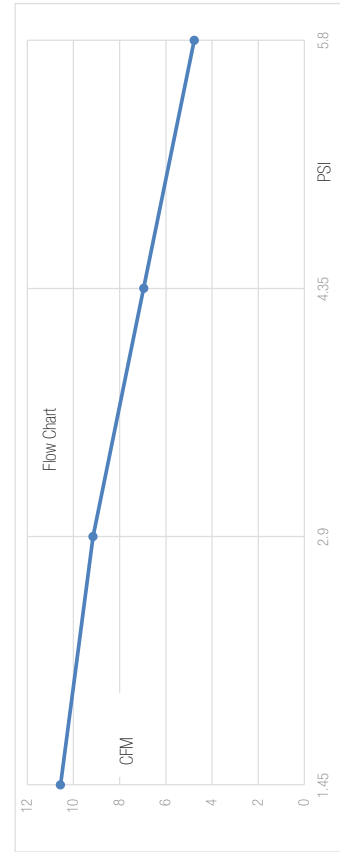

ECOPD-NR SERIES DATA PLATES

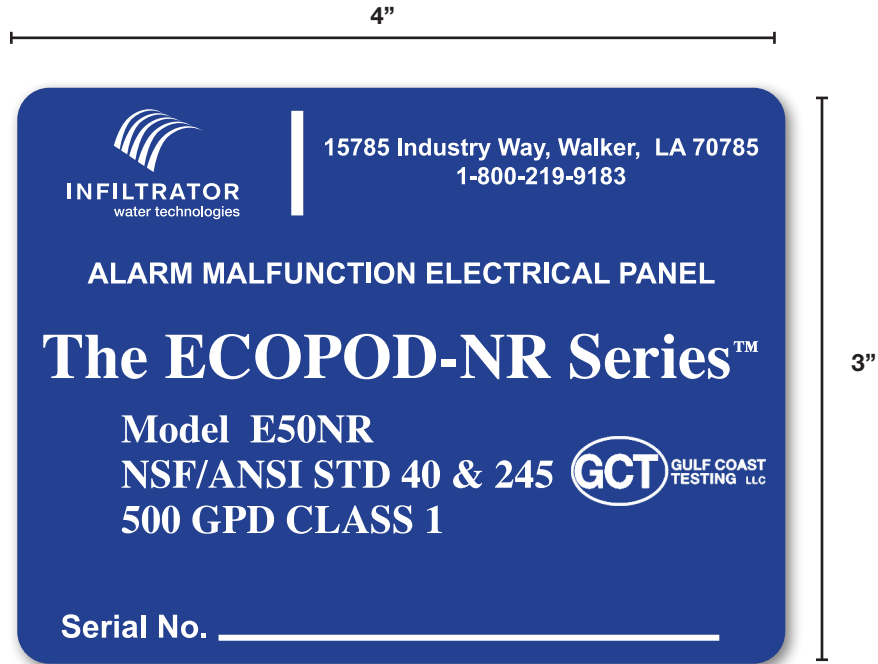
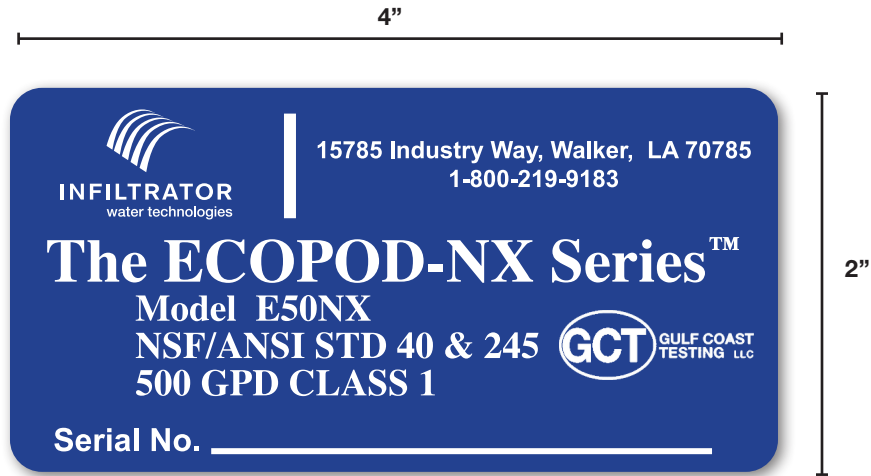

ECOPD-NX SERIES DATA PLATES

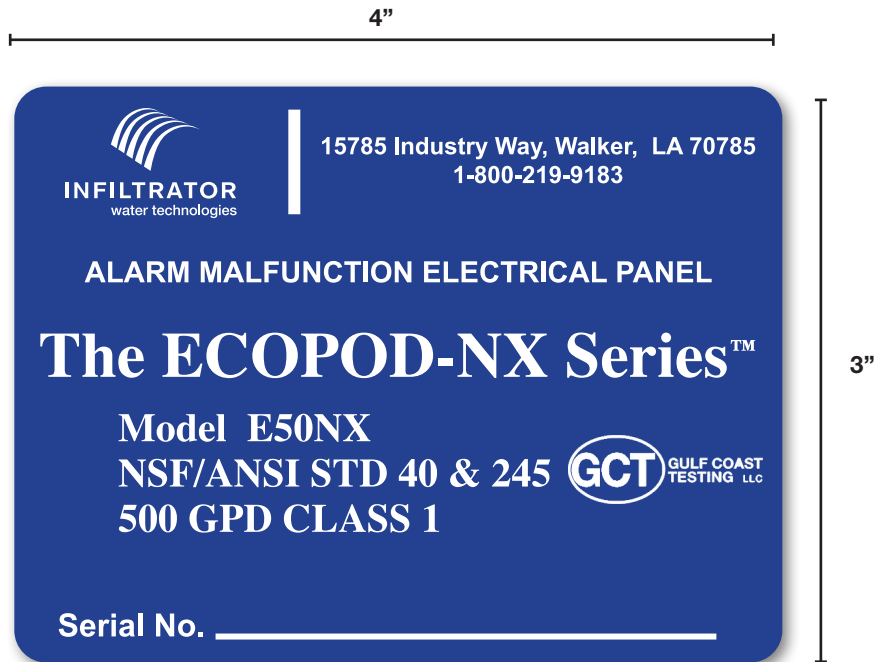
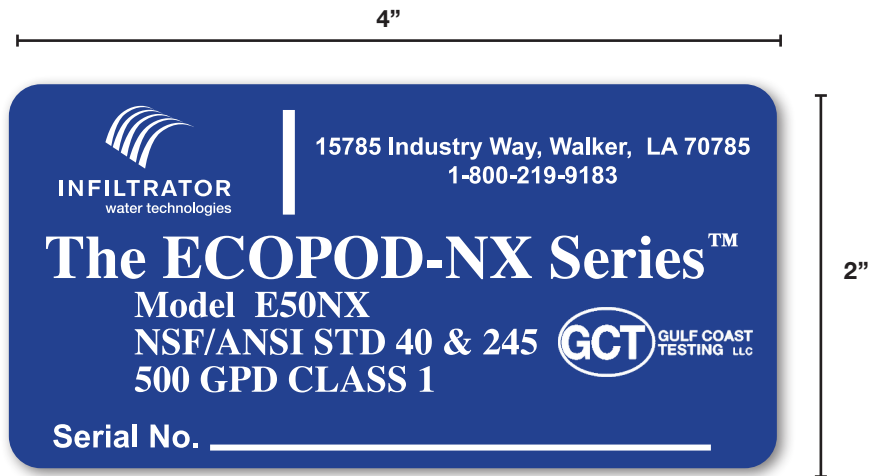

SERVICE POLICY

INFILTRATOR WATER TECHNOLOGIES INDIVIDUAL MECHANICAL WASTEWATER TREATMENT SYSTEM SERVICE POLICY

INITIAL POLICY:

A two-year initial service policy shall be furnished to the user by the manufacturer or the distributor through the dealer. This policy may be included in the price of the system, provided the state in which the system is being installed has adopted Gulf Coast Testing, LLC Certification Policies for Wastewater Treatment Devices as part of their state rules.

1. **An inspection/service call every six months**, which includes inspection, adjustment, and servicing of the mechanical and electrical component parts as necessary to ensure proper function.
2. An effluent quality inspection every six months consisting of a visual check for color, turbidity, scum overflow, and an examination for odors.
3. If any improper operation is observed that cannot be corrected at that time, the user shall be notified immediately in writing of the conditions and the estimated date of correction. **THIS POLICY DOES NOT INCLUDE PUMPING SLUDGE FROM UNIT IF DEEMED NECESSARY.**

CONTINUING SERVICE POLICY:

An annually renewable service policy affording the same coverage as the Initial Service Policy is available. Consult your dealer for pricing information. The annually renewable service policy should provide the same service checks as the initial Gulf Coast Testing service policy and should be performed twice per year, or as required by state or local requirements.

PARTS:

Replacement parts or components may be obtained from your local distributor or contact Infiltrator Water Technologies for information.

COMPLAINTS:

In order for Infiltrator Water Technologies to properly address complaints, we require that you put in writing the date and nature of the complaint as detailed as possible. This **MUST** include the serial number of your system.

Send to: Infiltrator Water Technologies
4 Business Park Road, P.O. Box 768
Old Saybrook, CT 06475-0768

WARRANTY

INFILTRATOR WATER TECHNOLOGIES, LLC (“INFILTRATOR”) INFILTRATOR TWO (2) YEAR ECOPOD® SERIES MATERIALS AND WORKMANSHIP LIMITED WARRANTY

- (a) This limited warranty is extended to the end user of a Infiltrator ECOPOD® Series Advanced Wastewater Treatment Product (the “ECOPOD® Product”). An ECOPOD® Product manufactured by Infiltrator, when installed and operated in accordance with Infiltrator’s installation instructions and local regulation by a licensed installer, is warranted to you: (i) against defective materials and workmanship for two (2) years after installation. Infiltrator will, at its option, (i) repair the defective product or (ii) replace the defective materials. This Warranty does not cover any damage caused by flooding, abuse, unauthorized disassembly, improper wiring or overload protection. This Warrant does not cover any of the house wiring, plumbing, drainage or disposal systems.
- (b) In order to exercise your warranty rights, you must notify Infiltrator in writing at its corporate headquarters in Old Saybrook, Connecticut within fifteen (15) days of the alleged defect. Infiltrator reserves the right to inspect the item to confirm that it is defective.
- (c) YOUR EXCLUSIVE REMEDY WITH RESPECT TO ANY AND ALL LOSSES OR DAMAGES RESULTING FROM ANY CAUSE WHATSOEVER SHALL BE SPECIFIED IN SUBPARAGRAPH (a) ABOVE. INFILTRATOR SHALL IN NO EVENT BE LIABLE FOR ANY CONSEQUENTIAL OR INCIDENTAL DAMAGES OF ANY KIND, HOWEVER OCCASIONED, WHETHER BY NEGLIGENCE OR OTHERWISE. SOME STATES DO NOT ALLOW THE EXCLUSION OR LIMITATION OF INCIDENTAL OR CONSEQUENTIAL DAMAGES, SO THIS LIMITATION OR EXCLUSION MAY NOT APPLY TO YOU. THIS WARRANTY GIVES YOU SPECIFIC LEGAL RIGHTS AND YOU MAY ALSO HAVE OTHER RIGHTS WHICH VARY FROM STATE TO STATE.
- (d) THIS LIMITED WARRANTY IS THE EXCLUSIVE WARRANTY GIVEN BY INFILTRATOR AND SUPERSEDES ANY PRIOR, CONTRARY, ADDITIONAL, OR SUBSEQUENT REPRESENTATIONS, WHETHER ORAL OR WRITTEN. INFILTRATOR DISCLAIMS AND EXCLUDES TO THE GREATEST EXTENT ALLOWED BY LAW ALL OTHER WARRANTIES, WHETHER EXPRESS OR IMPLIED, OR STATUTORY, INCLUDING ANY WARRANTY OF MERCHANTABILITY, FINESSE FOR A PARTICULAR PURPOSE AND ANY IMPLIED WARRANTIES OTHERWISE ARISING FROM COURSE OF DEALING, COURSE OF PERFORMANCE, OR USAGE OF TRADE. NO PERSON (INCLUDING ANY EMPLOYEE, AGENT, DEALER, OR REPRESENTATIVE) IS AUTHORIZED TO MAKE ANY REPRESENTATION OR WARRANTY CONCERNING THIS PRODUCT, EXCEPT TO REFER YOU TO THIS LIMITED WARRANTY. EXCEPT AS EXPRESSLY SET FORTH HEREIN, THIS WARRANTY IS NOT A WARRANTY OF FUTURE PERFORMANCE, BUT ONLY A WARRANTY TO REPAIR OR REPLACE DEFECTIVE COMPONENTS.
- (e) YOU MAY ASSIGN THIS LIMITED WARRANTY TO A SUBSEQUENT PURCHASER OF YOUR HOME.
- (f) NO REPRESENTATIVE OF INFILTRATOR HAS THE AUTHORITY TO CHANGE THIS LIMITED WARRANTY IN ANY MANNER WHATSOEVER, OR TO EXTEND THIS LIMITED WARRANTY BEYOND THE STATED TWO (2) YEAR TERM.
- (g) NO WARRANTY OF ANY KIND IS MADE WITH REGARD TO ANY PRODUCT, COMPONENTS, DEVICES, MEDIA OR TREATMENT UNITS WHICH ARE MANUFACTURED BY OTHERS AND ARE INSTALLED IN CONNECTION WITH THE ECOPOD® PRODUCT. USE OF THESE PRODUCTS ARE AT YOUR OWN RISK.

CONDITIONS AND EXCLUSIONS

There are certain conditions or applications over which Infiltrator has no control. Defects or problems as a result of such conditions or applications are not the responsibility of Infiltrator and are NOT covered under this warranty. They include failure to install the ECOPOD® Product in accordance with instructions or applicable regulatory requirements or guidance and altering the ECOPOD® Product contrary to the installation instructions.



INFILTRATOR
water technologies

4 Business Park Road
P.O. Box 768
Old Saybrook, CT 06475
(860) 577-7000 • Fax (860) 577-7001
(800) 221-4436
www.infiltratorwater.com
info@infiltratorwater.com

For U.S. Patents information visit www.infiltratorwater.com/patents. Other patents pending. Infiltrator, Quick4 and EZflow are registered trademarks of Infiltrator Water Technologies. Infiltrator Water Technologies is a wholly-owned subsidiary of Advanced Drainage Systems, Inc. (ADS).

IWT4509NX 03/2024 © 2024 Infiltrator Water Technologies, LLC. Not responsible for any typographic errors. Printed in U.S.A.

Contact Infiltrator Water Technologies Technical Services Department at (800) 221-4436 or info@infiltratorwater.com