

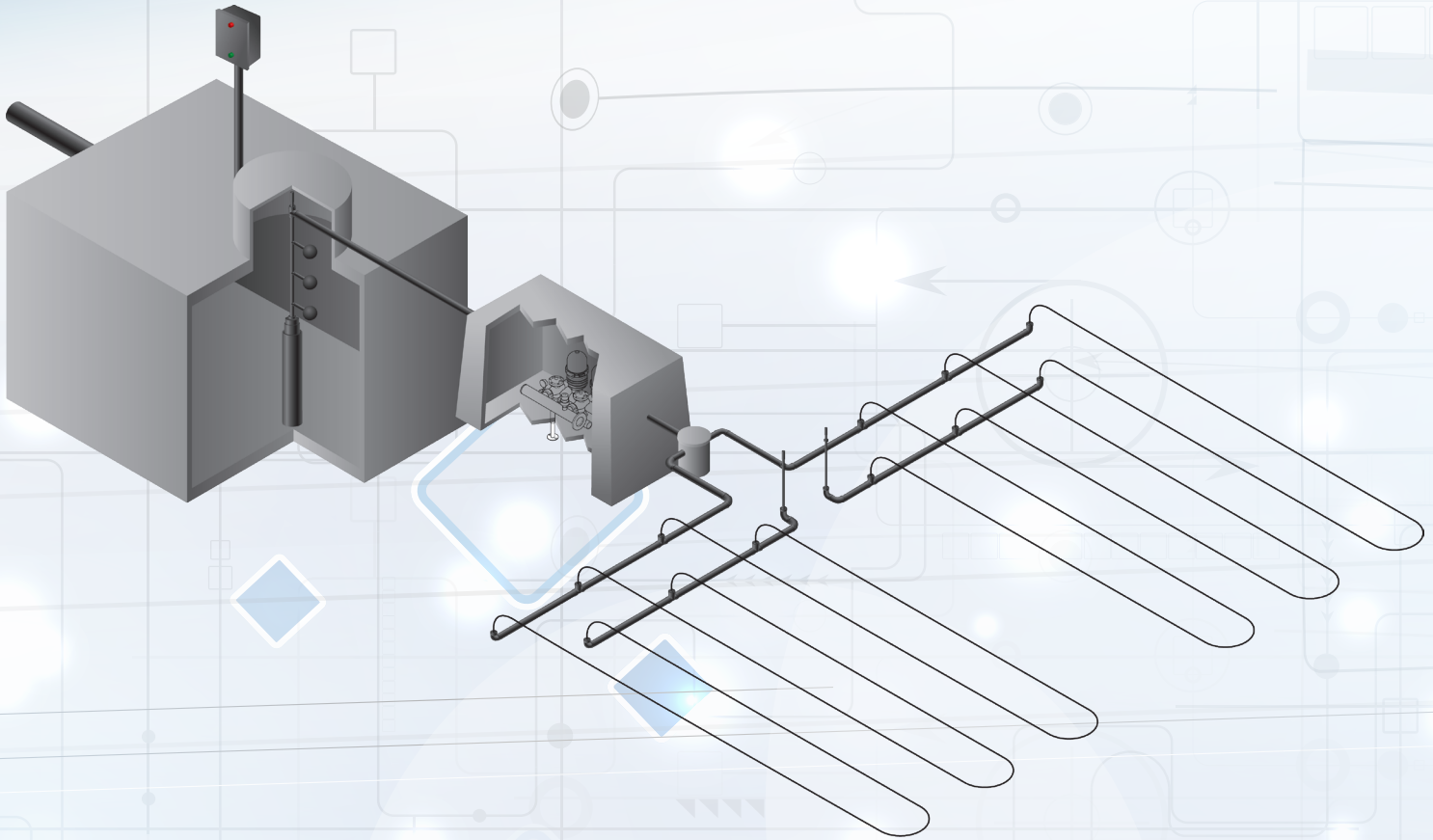

INFILTRATOR
water technologies



INFILTRATOR WATER TECHNOLOGIES
ECODRIP[®]
COMMERCIAL ENGINEERED
WASTEWATER DRIP
DISPOSAL SYSTEM

INFILTRATOR WATER TECHNOLOGIES

Commercial Engineered Wastewater Drip Disposal System

Complete Engineered Drip Disposal Systems

Design, layouts, controls, filter systems, and all necessary components



Models Up To 100,000 GPD

Engineered package includes: Drip Series CP 12000 filter controller, float level switches, filter assembly, high head pumps, zone valves, emitter tubing, pressure regulators, vacuum/air release valves, and emitter tube fittings.

Filter System Controls

The CP 12000 series control panel utilizes a programmable logic controller (PLC) to automate all functions in a NEMA 4X hinged door enclosure. The PLC provides:

- Optional filter/field drain feature
- Multiple power
- Multiple zone capability circuits compatibility
- Adjustable override dosing times
- Override counter
- Accepts 2, 3 or 4 float arrangements
- High level counter
- Simplex and duplex
- Switch to hand counter

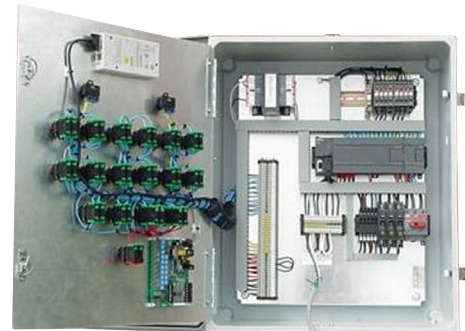

All features are field adjustable without the need of additional equipment. Features can be added when needed.

Filter Assembly

The filter assembly provides:

- 100 micron filtration
- Effluent metering
- Filter and field flush valves



The disc filter ensures both long life and easy maintenance. The effluent meter provides monitoring of system flow. Remote control valves are located in the filter assembly, thus providing access for installation and maintenance. The filter assembly is constructed of components that have been selected specifically for effluent wastewater applications.

The Intelligent Choice in Drip Technology

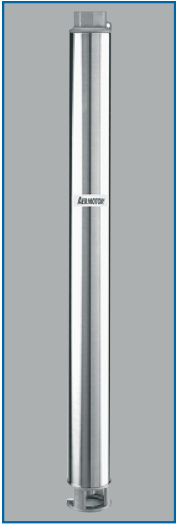

Submersible High Head Pumps

To meet the demanding requirements of drip disposal, stainless steel effluent wastewater high head pumps are provided. These pumps have precision molded impellers in diffuser stages fitted with stainless wear rings. The pumps have a nylon discharge head and a polyethylene intake screen specifically for effluent wastewater applications.

Zone Valves

Zone valves allow multiple drip zones per system.



Vacuum /Air Release Valves

Prevents air locks and back siphoning throughout the drip system.

Drip Emitter Tubing

In either non-pressure or pressure compensating emitters and designed for effluent wastewater applications, flow rates are available from .53 to 1.3 gallons per hour.



Tube Fittings and Components

All components needed to construct a drip disposal system are available.

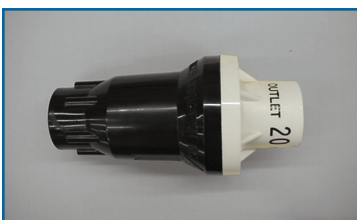

Pressure Regulators

Pressure regulators can be provided to maintain correct operating pressure in the drip emitter tube.

Other Advanced Treatment Systems

A respected leader in wastewater treatment with decades of technical design and manufacturing experience, Infiltrator Water Technologies is committed to the continuing development of new products in the 21st century.

Application

At Infiltrator Water Technologies, our engineers have designed wastewater systems for many years, and all are field-tested. We have applied our vast experience in building residential and industrial wastewater systems to bring you the Infiltrator Water Technologies ECOFILTER.

This system efficiently removes solids, which translates into improved wastewater quality. In addition, the Infiltrator Water Technologies ECOFILTER prolongs the life of downstream treatment systems. The system is completely engineered and designed to meet your specifications. You have the choice of pumps, floats, enclosure size and control panels. You have the peace of mind knowing that an industry leader built your system.

Technical Support/Distributor Network

Distributors and corporate technical support are ready to help you with any questions. Infiltrator Water Technologies has distributors around the country. Each of these professionals is factory-trained on the Infiltrator Water Technologies ECOFILTER to provide the help you need. The network of support included with your purchase of the Infiltrator Water Technologies ECOFILTER is second to none. The distributors of Infiltrator Water Technologies are ready to provide the service you expect.



4 Business Park Road
P.O. Box 768
Old Saybrook, CT 06475
(860) 577-7000 • Fax (860) 577-7001
(800) 221-4436
www.infiltratorwater.com
info@infiltratorwater.com

For U.S. Patents information visit www.infiltratorwater.com/patents. Other patents pending. Infiltrator, Quick4 and EZflow are registered trademarks of Infiltrator Water Technologies. Infiltrator Water Technologies is a wholly-owned subsidiary of Advanced Drainage Systems, Inc. (ADS).

IWT-036 03/2024 © 2024 Infiltrator Water Technologies, LLC. Not responsible for any typographic errors. Printed in U.S.A.